

# faru

# PERMANENT ANCHORAGE SYSTEMS

# 3

- Permanent anchor points
- Anchor posts
- Horizontal line systems
- Horizontal rail systems
- Vertical line systems
- Vertical rail system
- Safety ladders
- Safety barriers
- Skylight security system
- Mobile man anchor



2022/23



®

PROTECT YOUR LIFE | USE IMAGINATION



## Contents:

- 8** Introduction to fixed safety installations
- 15** Anchor points
- 22** Anchor posts
- 28** Anchor posts PROTON
- 38** PRIM
- 46** DUO
- 58** PROLINER
- 62** MONOLINE
- 68** TRASER
- 72** MARAN
- 78** SKC BLOCK
- 80** AC 360
- 88** AC 520
- 94** AC 510
- 98** PROSAFE
- 106** AT 242
- 108** Anchor mass



Devices and systems manufactured provide work safety in conditions where risk of fall from a height is present.

This equipment is used in many industries for works at a height, depth and in providing rescue services. Our offer includes both components of personal fall protection equipment - full body harnesses, energy absorbers, lanyards, and permanent anchorage systems, all included in this catalogue. We pay special attention to comfort of use and reliability in functioning of our devices, making efforts to meet our customers' still growing needs as best as possible. All our products hold European certificates of conformity and relevant approvals. For detailed, up-to-date functional and technical information, please contact the company's office or a technical and commercial consultant.



# CLASSIFICATION OF ANCHORAGE SYSTEMS

## Anchorage points and posts

	● ● ●		
Anchorage points		AT 150	AT 180
		AT 151	AT 181
		AT 152	AT 183
		AT 153	AT 185
			AT 187
			AT 198
Anchor posts		HL700	PROTON1
		HLB700	PROTON2
		HLP700	PROTON4A,B,C,D
			PROTON5

## Horizontal mobility

Line systems		System Prim
		System Duo
		System Monoline
		System Proliner
Rail systems		System Traser
		System Maran
Railings		System Prosafe

## Vertical mobility

Line systems		SKC BLOCK
		AC 360
Rail systems		AC 520
Safety ladders		AC 510



## Installing and servicing of anchorage systems



Customer who wishes to install an anchorage system on his/her site should first contact us technical and commercial consultant to discuss protection systems and obtain necessary data and materials, have a technical concept of protection system and an offer prepared. Then our consultant will draw technical concept for a protection system and send the Customer a trade offer. Following acceptance of conditions given the Customer should submit a written order for delivery of materials and installation. Once this order is received, our consultant contacts works coordinator on behalf of the Customer to settle the works schedule. The installed systems should be subject to inspections carried out no less than once every 12 months by us or an authorized service point. For inspection and servicing, please contact our Servicing Department.



# Permanent fall protection systems

## Regulations and standards

If no collective fall protection system is used on a site, the regulations stipulate to use personal fall protection equipment in combination with permanent anchorage systems designed so the user can reach work station and perform the job safely.

The user must be equipped with protective devices limiting maximum dynamic forces applied on the user while arresting a fall to maximum 6kN, according to EN 363 and EN 795.

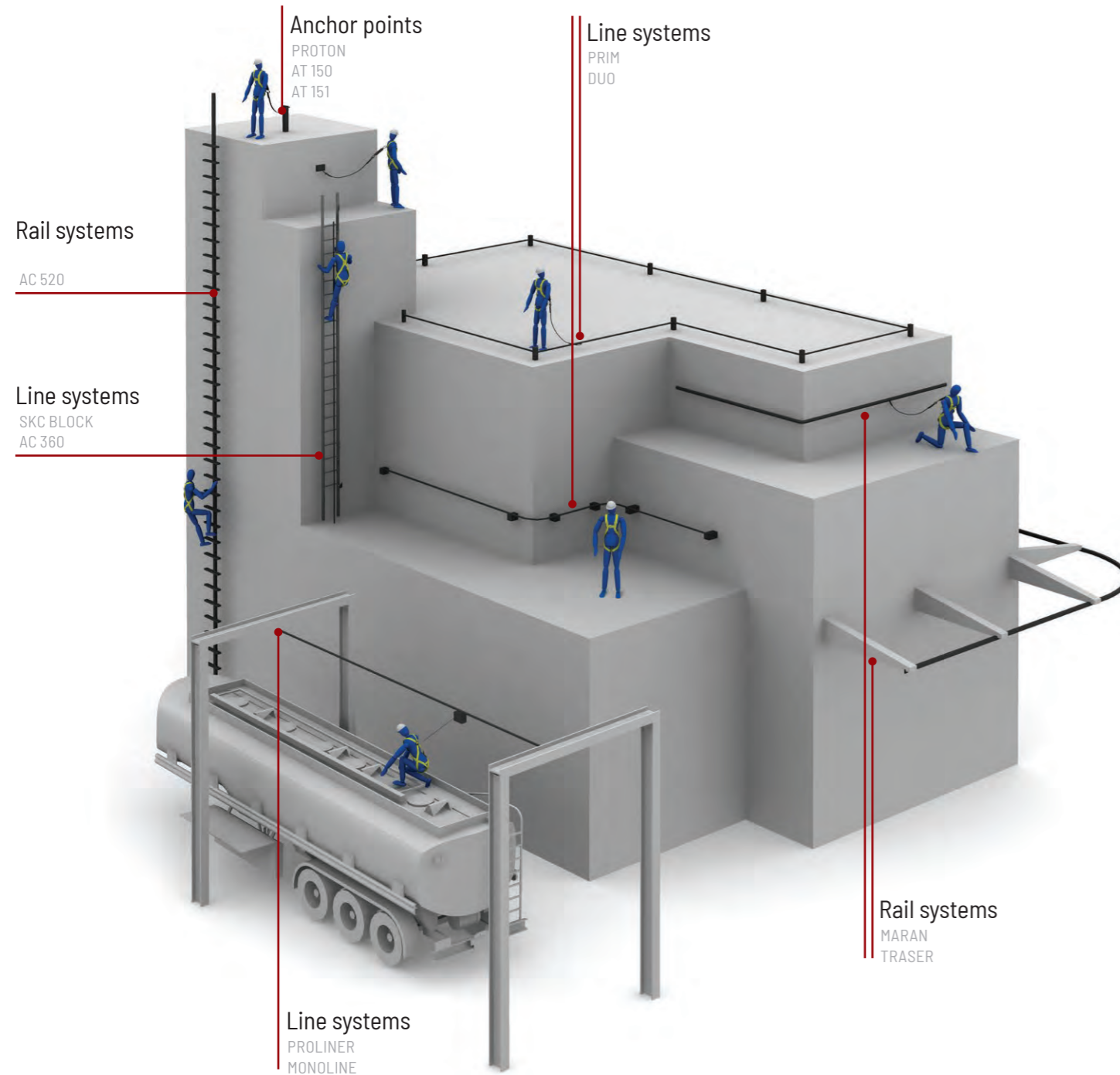

## Types of permanent fall protection systems

- **ANCHOR POINTS**  
Standards: EN 795:2012 CEN / TS1645:2013 Type A  
Devices with fixed anchor points for one or more users fixed to a load-bearing structure.
- **HORIZONTAL LIFELINES**  
Standards: EN 795:2012 CEN / TS1645:2013 Type C  
Devices with fixed anchor points for one or more users fixed to a load-bearing structure.
- **HORIZONTAL LIFELINES**  
Standards: EN 795:2012 CEN / TS1645:2013 Type C  
Devices as a flexible anchor line tilted in relation to the horizontal by max. 15°, mounted on a load-bearing structure at both ends, and optionally in intermediate points along the anchor line. They enable the user to move horizontally along a track determined by flexible anchor line. Designed for one or more users.
- **HORIZONTAL ANCHOR RAILS**  
Standards: EN353-1:2014  
Devices as a rigid anchor line tilted in relation to the horizontal by max. 15° and mounted on a load-bearing structure. They enable the user to move horizontally along a track determined by rigid anchor line. Designed for one or more users.

The PROTEKT products are subject to both **static** and **dynamic** testing.

Anchor devices are statically and dynamically tested in accordance with: EN 795:2012 and CEN / TS 16415:2013

Loads used during laboratory testing of anchor devices.			
Number of co-users	Static test	Dynamic test	Integrity test*
1 user	12 kN	Dynamic load of 100kg	3 kN
2 users	13 kN	Dynamic load of 200 kg	6 kN
3 users	14 kN	Dynamic load of 100kg + static load of 200kg	7,5 kN
4 users	15 kN	Dynamic load of 100kg + static load of 300 kg	9 kN

\*) - integrity test is a static test carried out on the same sample, directly after the dynamic test.

Vertical anchor systems are statically and dynamically tested in accordance with: EN 353-1:2014

Loads used during laboratory testing of vertical anchor systems.		
Number of co-users	Static test	Dynamic test
1 user	15 kN	Dynamic load of 100kg**
2 users	16 kN	Dynamic load of 100kg** + static load of 100kg**

\*\*)- devices for users with a weight of more than 100kg are tested by applying loads equal to maximum weight of the user.

A general algorithm **for designing** of permanent anchorage systems.

## 1

### RISK ANALYSIS

- identification of places where a potential fall may occur
- size of free space in a place where a potential fall may occur
- expected climatic conditions when working

## 2

### ANALYSIS OF GEOMETRY AND STRUCTURE

- shape of construction
- arrangement of load-bearing elements of a structure which may be used to fix a fall protection system

## 3

### METHOD OF WORKING AND MOVING

- type of work performed
- moving routes
- place of access to permanent anchorage system
- frequency of work performed
- number of workers performing works at the same time

## 4

### SELECTION OF TYPE OF ANCHORAGE SYSTEM

## 5

### ARRANGEMENT OF ANCHORAGE SYSTEM ON SITE

## 6

### VERIFICATION OF STRENGTH OF SYSTEM MOUNTING TO FIXED STRUCTURE

- determination of values of design loads acting on mounting
- checking of limit strength of mountings

## General rules

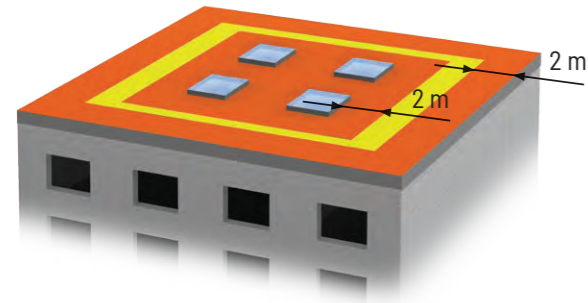

Potential place where a fall may occur:

- edge of roof,
- openings in roof and roof windows
- roof areas of a low strength

A higher risk is present over the whole area but the major danger is within approx. 2m from the above places.



 - area of significant risk of a fall

## ARRANGEMENT OF ANCHORAGE SYSTEM ON A FLAT ROOF

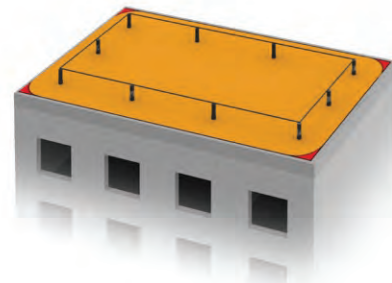
The **best** solution for all dimensions (x, y) of roof



- advantage: the largest roof area "covered" by the system,
- potential disadvantage: may hamper removal of snow from the roof.

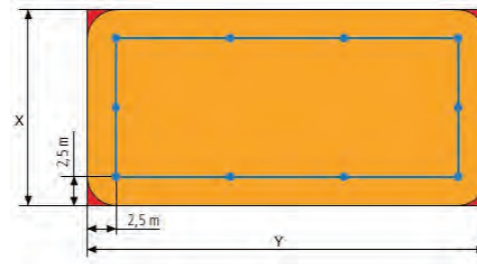

 - area of significant risk of a fall  
 - area covered by anchorage system

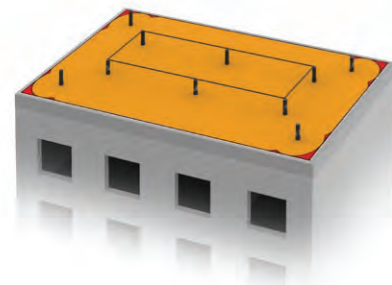

**Alternative** solution for dimensions  $x > 20m$ ;  $y > 20m$  of roof



- requires additional anchor points on corners in order to extend the protected roof area,
- advantage: larger distance of the system from roof edge makes snow removal easier,
- potential disadvantage: larger distance of the system from roof edge requires use of a longer personal connecting component.

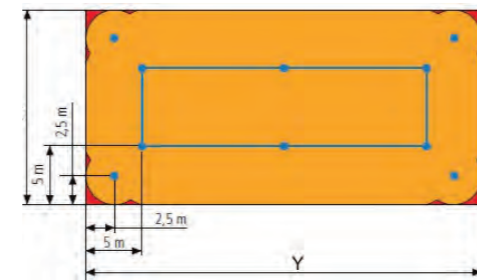

 - area of significant risk of a fall  
 - area covered by anchorage system

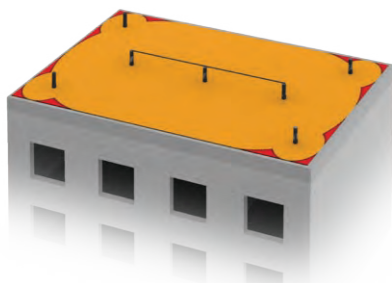

**Alternative** solution for dimensions  $x < 20m$ ;  $y > 20m$  of roof



- the smallest area of roof covered by the system
- requires additional anchor points on corners in order to extend the protected roof area,
- advantage: single system line hampers removal of snow from the roof as least as possible,
- potential disadvantage: larger distance of the system from roof edge requires use of a longer personal connecting component.

 - area of significant risk of a fall  
 - area covered by anchorage system

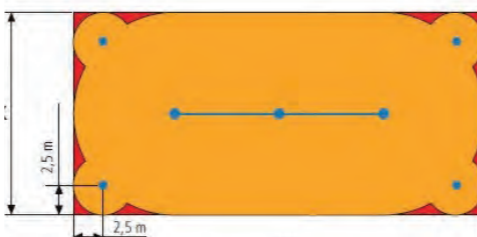

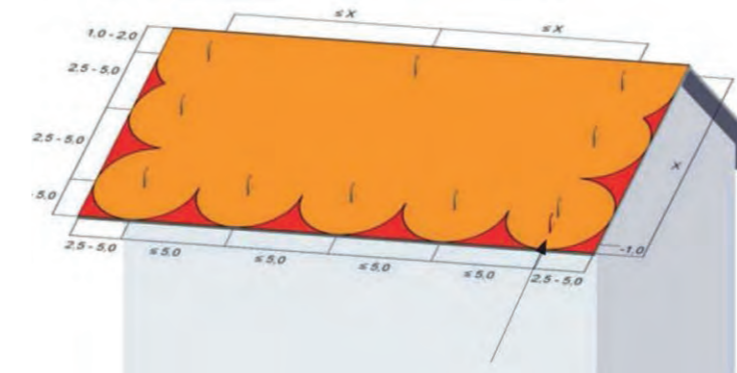

## ARRANGEMENT OF ANCHORAGE SYSTEM ON GABLE ROOF

Anchorage system as **anchor points**





- Anchor points spaced every 2.5m to 5m along side edges and lower edge of the roof.
- Along the ridge anchor points are spaced at distances equal to or less than side edge of the roof.

 - area of significant risk of a fall  
 - area covered by anchorage system

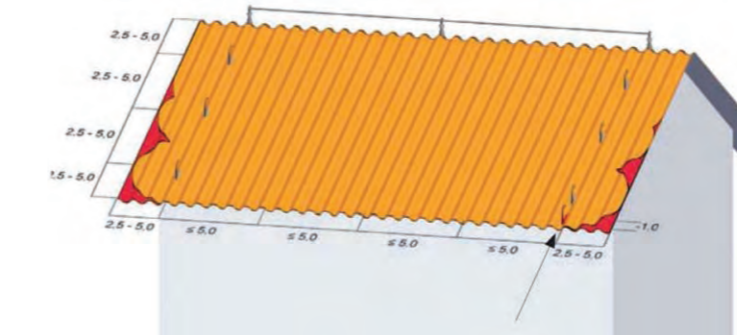
Anchorage system as a combination of **anchor points** and **safety horizontal line**.



- Anchor points spaced every 2.5m to 5m along side edges of the roof.
- On the ridge safety horizontal line (or rail) is installed allowing for mobility along the roof.

 - area of significant risk of a fall  
 - area covered by anchorage system

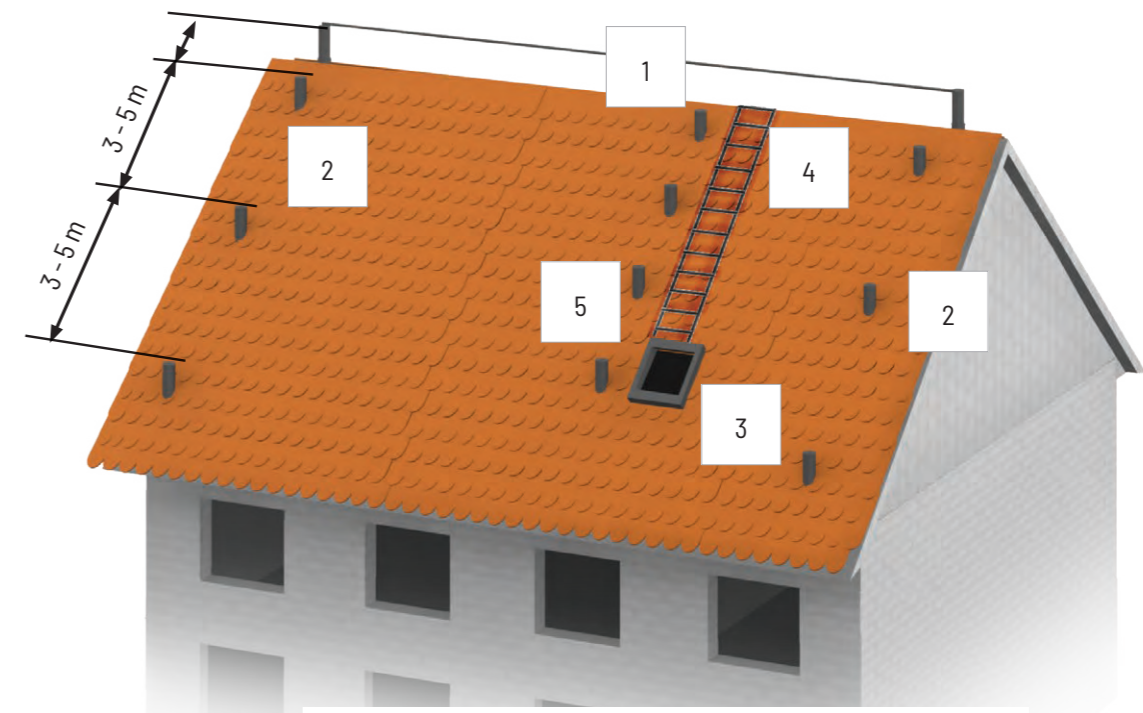

- 1 - Horizontal anchorage system as a main anchorage system on site
- 2 - Anchor points as protection of side edges of the roof
- 3 - Roof hatch
- 4 - Route to reach main anchorage system on the ridge
- 5 - Anchor points designed for protection when reaching the ridge





**AT 020**

L [mm]	X [mm]
180	43
200	63
220	83
240	103

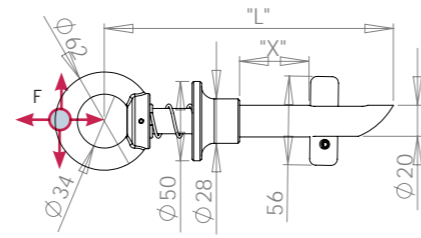

AT-020 anchor Point is an anchorage device type B, conform to the EN795: 2012 standard. It is designed for connecting a PPE system against fall from a height to a fixed construction. The AT-020 anchor post may be used by single user. The AT-020 is made of steel and aluminium alloy. The AT-020 anchorage point is intended for installation on a vertical, horizontal or inclined surface. It can be fasten to a fixed structure inside special prepare hole.



**AT 021**

The AT021 anchorage point is a component of fall protection equipment according to EN 795:2012 as type B anchorage device. It is used to connect a connecting and damping component (e.g. safety shock absorber with cable, self-locking devices, working ropes of self-locking sliding devices). The AT021 is a portable device and can only be installed in suitably prepared holes. The device is intended for use by a maximum of 1 person at a time.

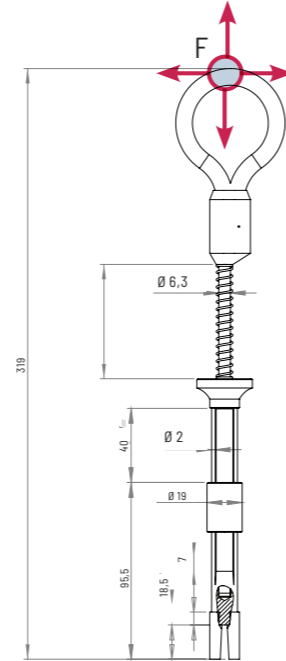

The AT021-T anchorage point is a fall protection device according to EN 795:2012 as a type B anchorage device. It is used to connect the connection and damping element (e.g. safety damping with cable, self-locking devices, working lines of self-locking slide devices). The AT021-T is a portable device and can only be installed in suitably prepared holes. The technical opening has been additionally secured with a steel bail in 5 available colours. The device is designed for use by up to 1 person at a time.



**AT 021-T**

AVAILABLE COLORS:

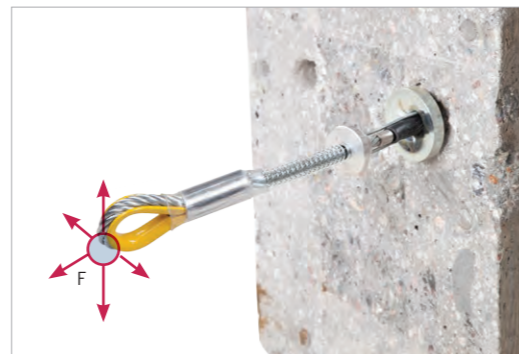

## AT 024 - Anchor point

Maximum 2 users

The AT 024 plug-in anchor allows for effective anchoring of personal fall protection equipment to fixed structures. The basic components of the system are the lifting eye AT024-A and the socket AT024-B. All load-bearing parts of the anchor are made of stainless steel. The lifting eye (AT024 A) is designed so that it can be removed from its socket (AT 024 B) at the press of a button and transferred to another socket.

The AT024-B sockets are permanently installed in a fixed structure. For mounting in a metal base, the AT024-D kit (nut with washer) is used. A single coupling eye can be connected to multiple sockets located in different parts of the building and removed after use. When not in use, the sockets are covered with the aesthetically pleasing end caps AT024-F.

### TECHNICAL DATA

- Max. number of simultaneous users: - 2 person
- Static strength: not less 13 kN.

### STANDARDS:

- EN 795:2012 - type A
- CEN/TS 16415:2013-type A

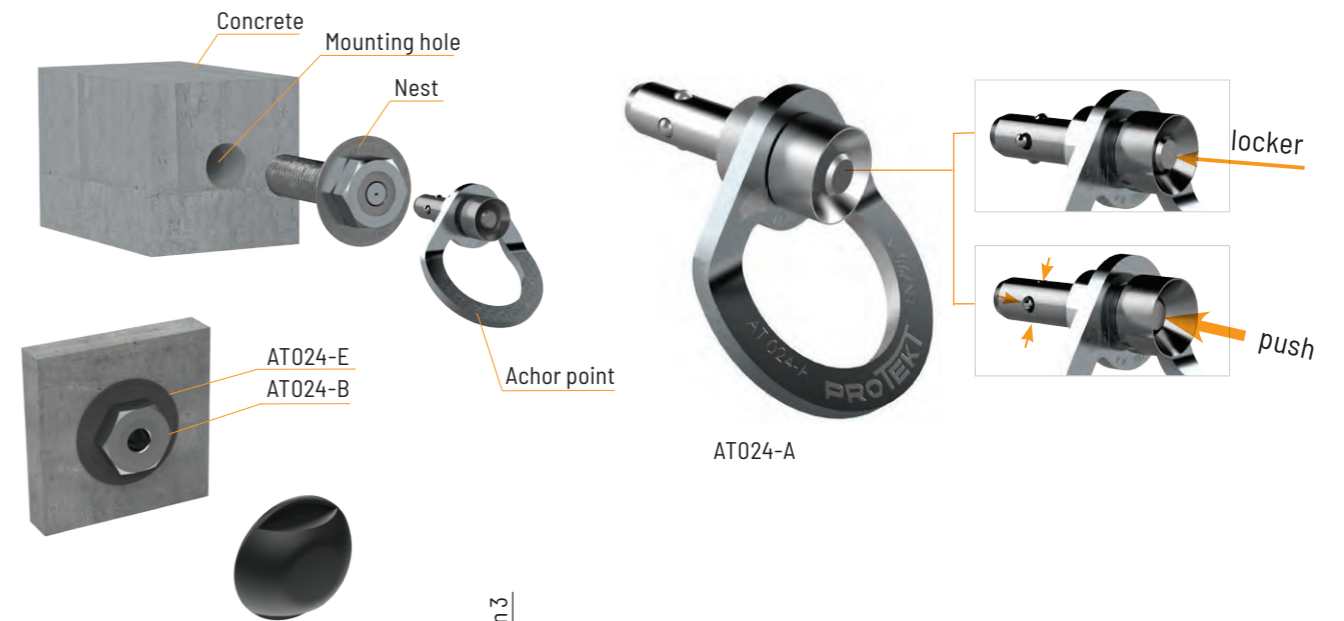
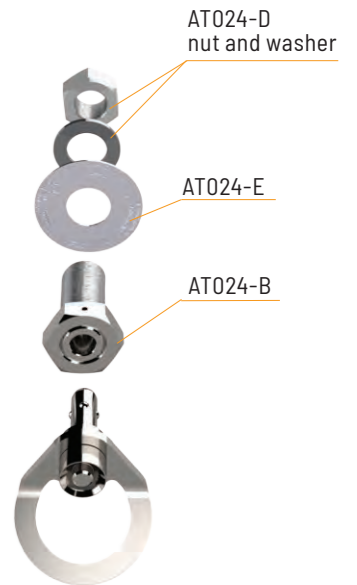

Attachment to steel element

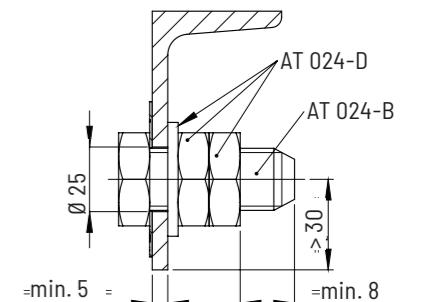
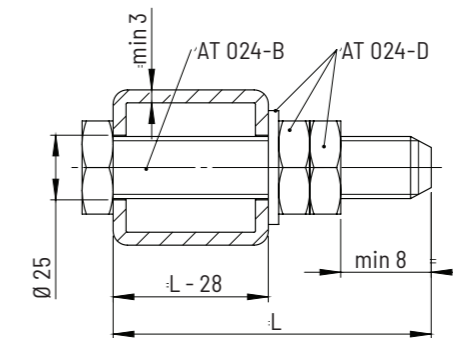

Attachment to concrete substrate

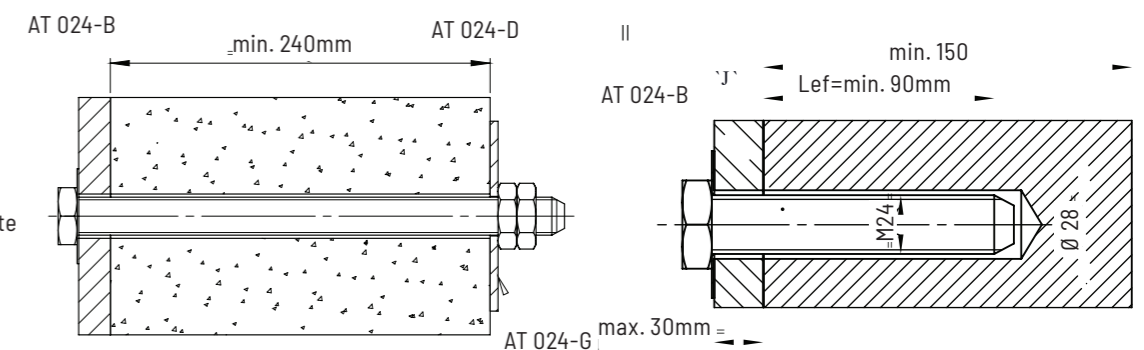

**AT 185 - Anchor point**

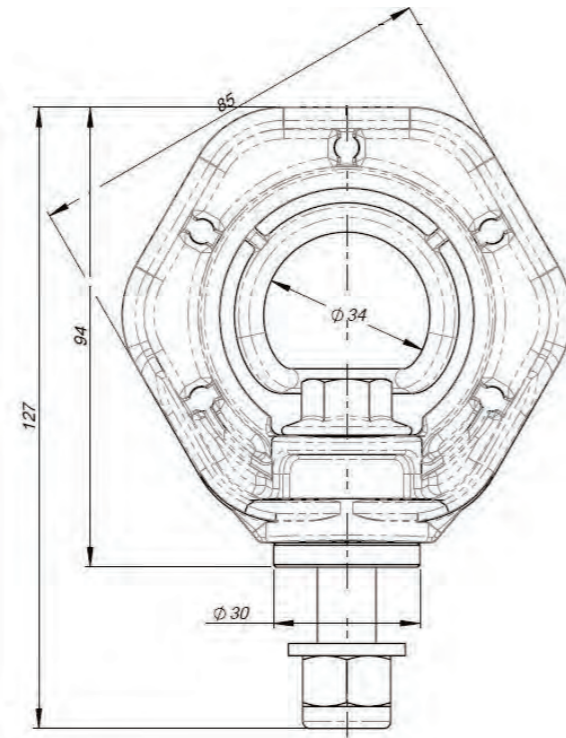
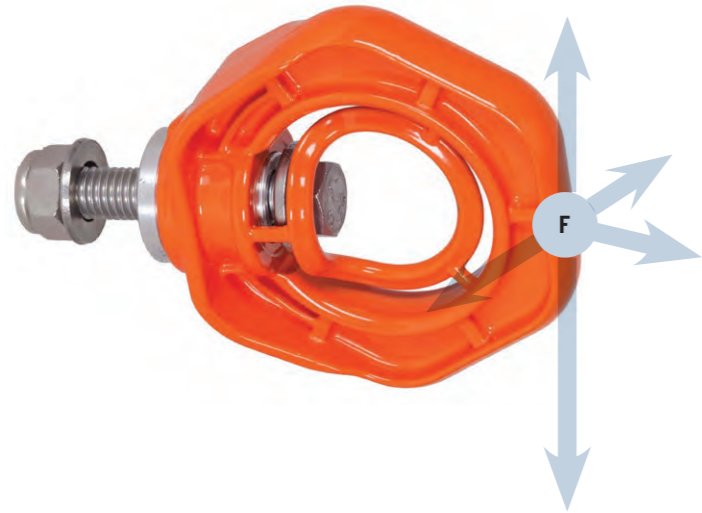

**DEVICE EQUIPPED IN FALL INDICATOR**

The anchor point AT185 is an anchor device according to EN 795 type A and serves to protect three people at the same time. The AT185 anchorage point may only be used as personal protective equipment against falls from a height and cannot be used to lift loads. The device is made of AISI304 stainless steel casting and an aluminium sleeve on which the device can be freely rotated. According to EN 795:2012 type A, the static strength of this point is min. 14 kN. The user must be provided with an element limiting the maximum dynamic forces acting on him/her during the fall arrest to a maximum of 1,5 m/s. The user must be provided with an element limiting the maximum dynamic forces acting on him/her during the fall arrest.

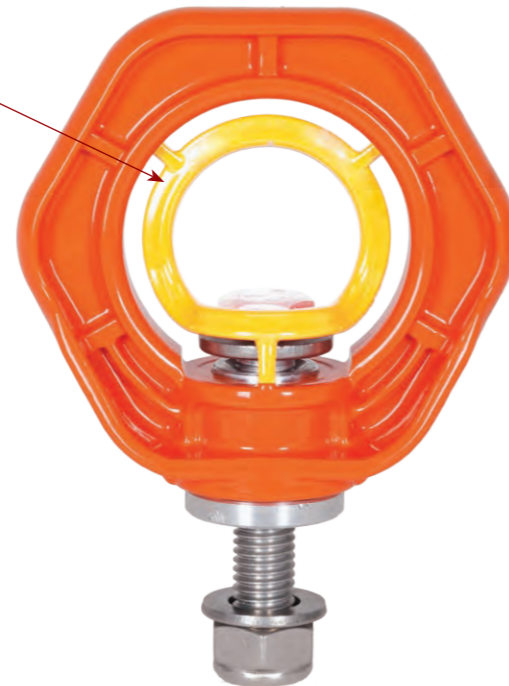

**STANDARDS:**  
- EN 795:2012 - type A

**TECHNICAL DATA**  
- Max. number of simultaneous users: - 3 person  
- Static strength: not less 14 kN.

**AT 187 - Anchor point**

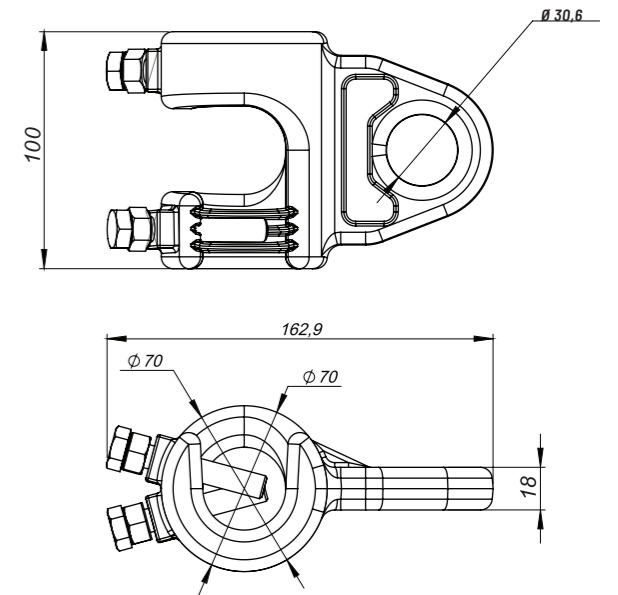
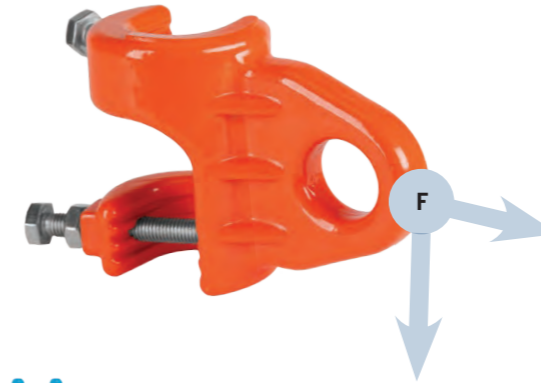

The AT187 anchor point is a type B anchor device according to EN 795 and serves to protect three people working at the same time. The AT187 Anchorage Point may only be used as personal protective equipment against falls from a height and cannot be used to lift loads. The device is made of steel. The strength of this point is min. 30 kN. The device is designed to be installed on a ribbed rod with a core diameter of up to 32 mm.

**EXAMPLE OF MOUNTING AN ANCHOR POINT ON A VERTICAL BAR**

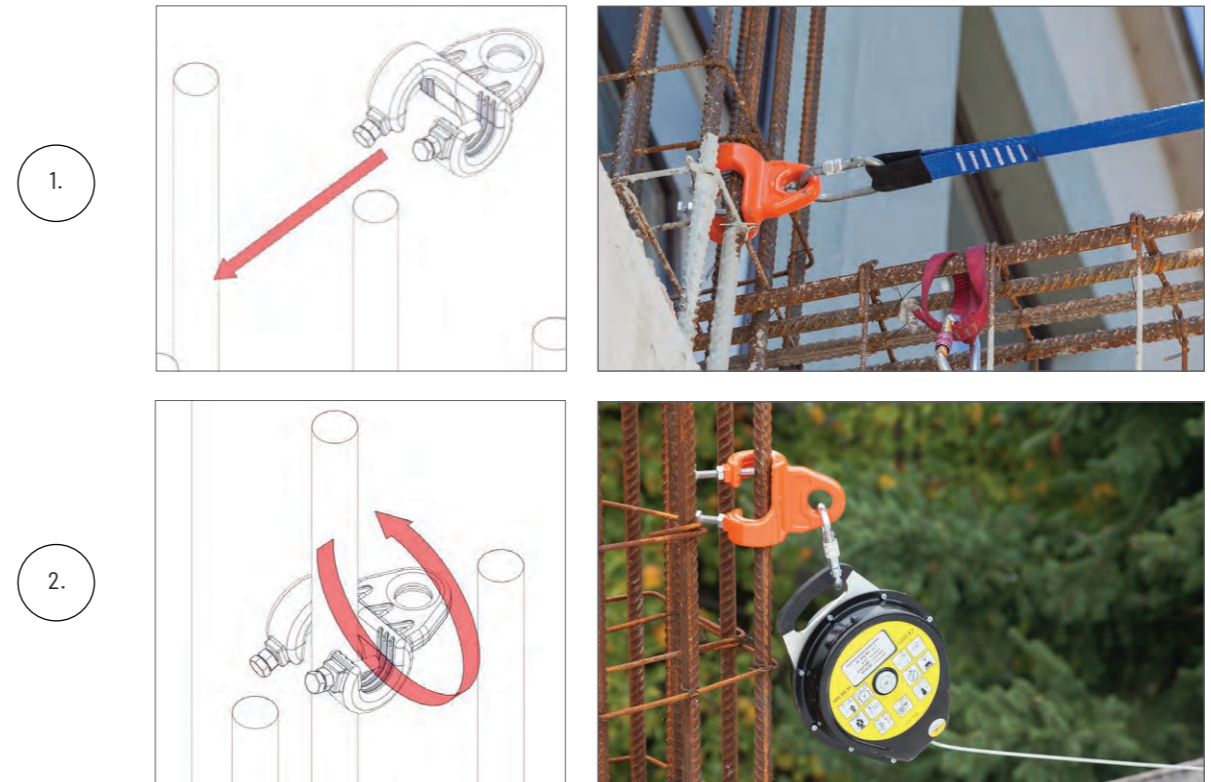

**STANDARDS:**  
- EN 795:2012 - type A

**TECHNICAL DATA**  
- Max. number of simultaneous users: - 3 person  
- Static strength: not less 30 kN.

# Anchor points

## AT 020 - Anchor point

AT-020 anchor point is an anchorage device type B, conform to the EN795:2012 standard. It is designed for connecting a PPE system against fall from a height to a fixed construction. The AT-020 anchor post may be used by single user. The AT-020 is made of steel and aluminium alloy. The AT-020 anchorage point is intended for installation on a vertical, horizontal or inclined surface. It can be fasten to a fixed structure inside special prepared hole.

L [mm]	X [mm]
180	43
200	63
220	83
240	103

AT 020



Dimensions

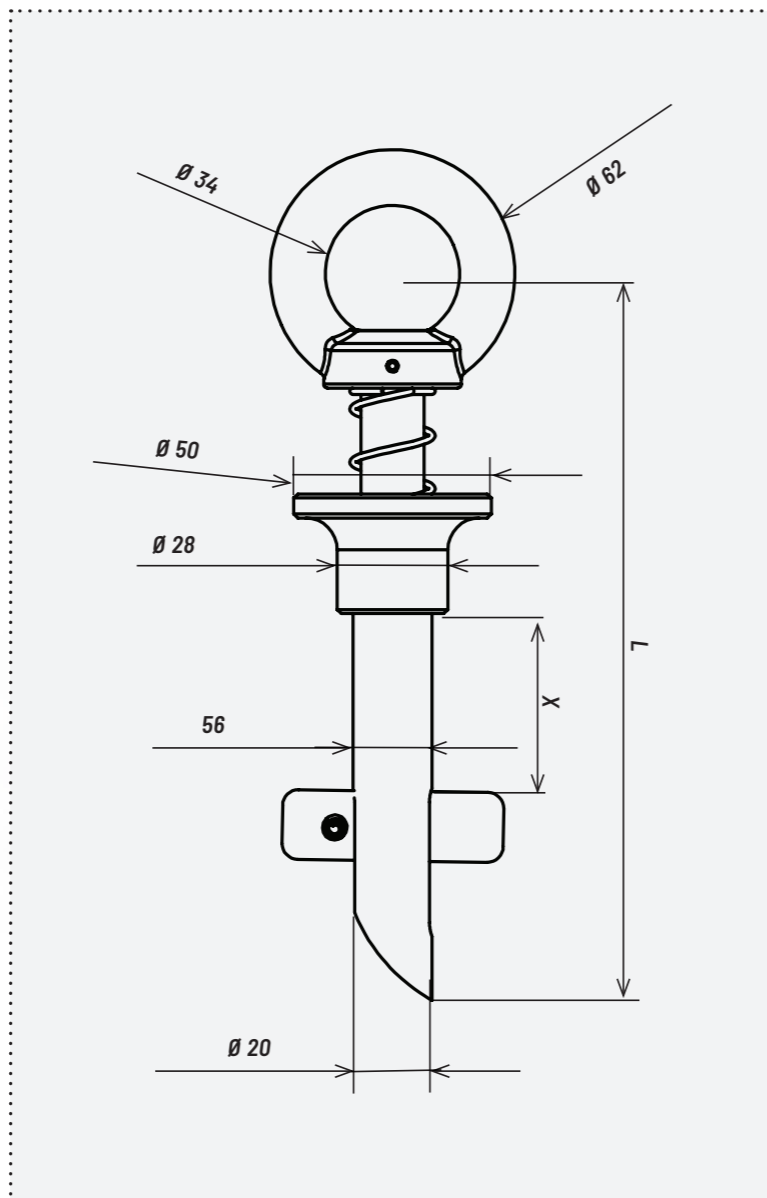

## AT 021 - Anchor point



The AT021 anchorage point is a component of fall protection equipment according to EN 795:2012 as type B anchorage device. It is used to connect a connecting and damping component (e.g. safety shock absorber with cable, self-locking devices, working ropes of self-locking sliding devices). The AT021 is a portable device and can only be installed in suitably prepared holes. The device is intended for use by a maximum of 1 person at a time.

AT 021



Maximum  
1 user

Dimensions

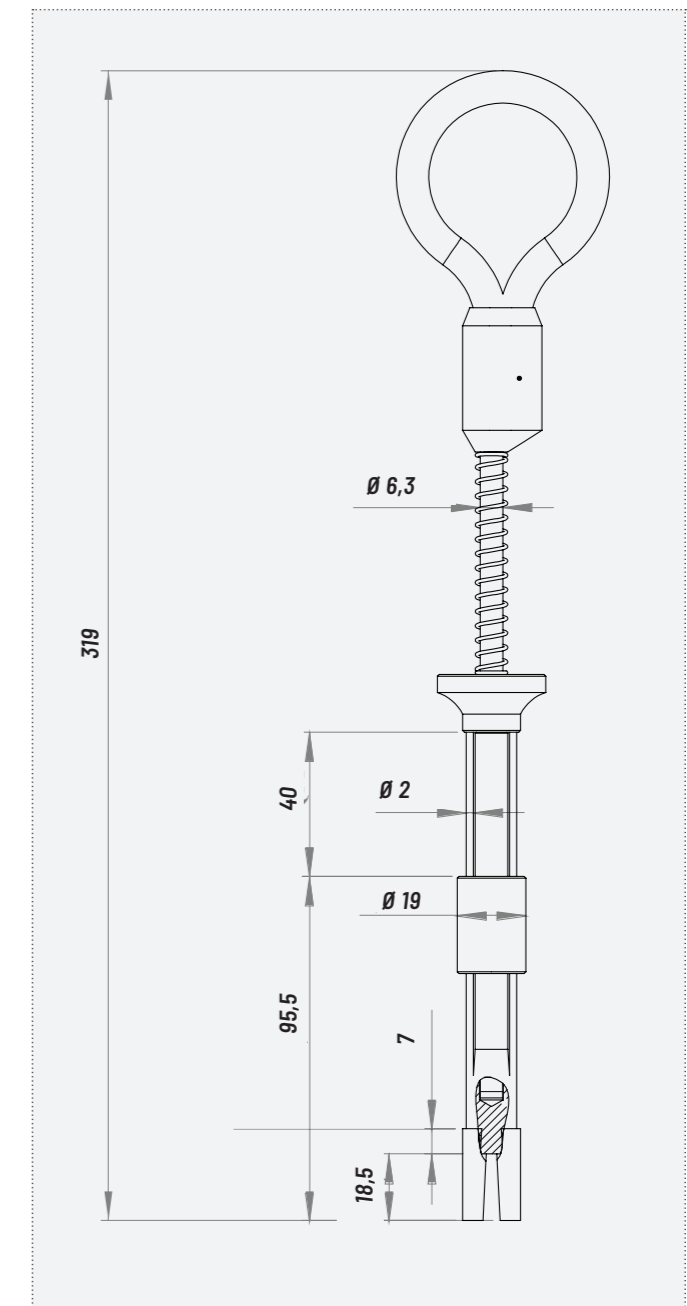

# AT 198

EN 795/A, CEN/TS 16415:2013

Anchorage point for trapezoidal metal sheet

Protection for up to 3 persons

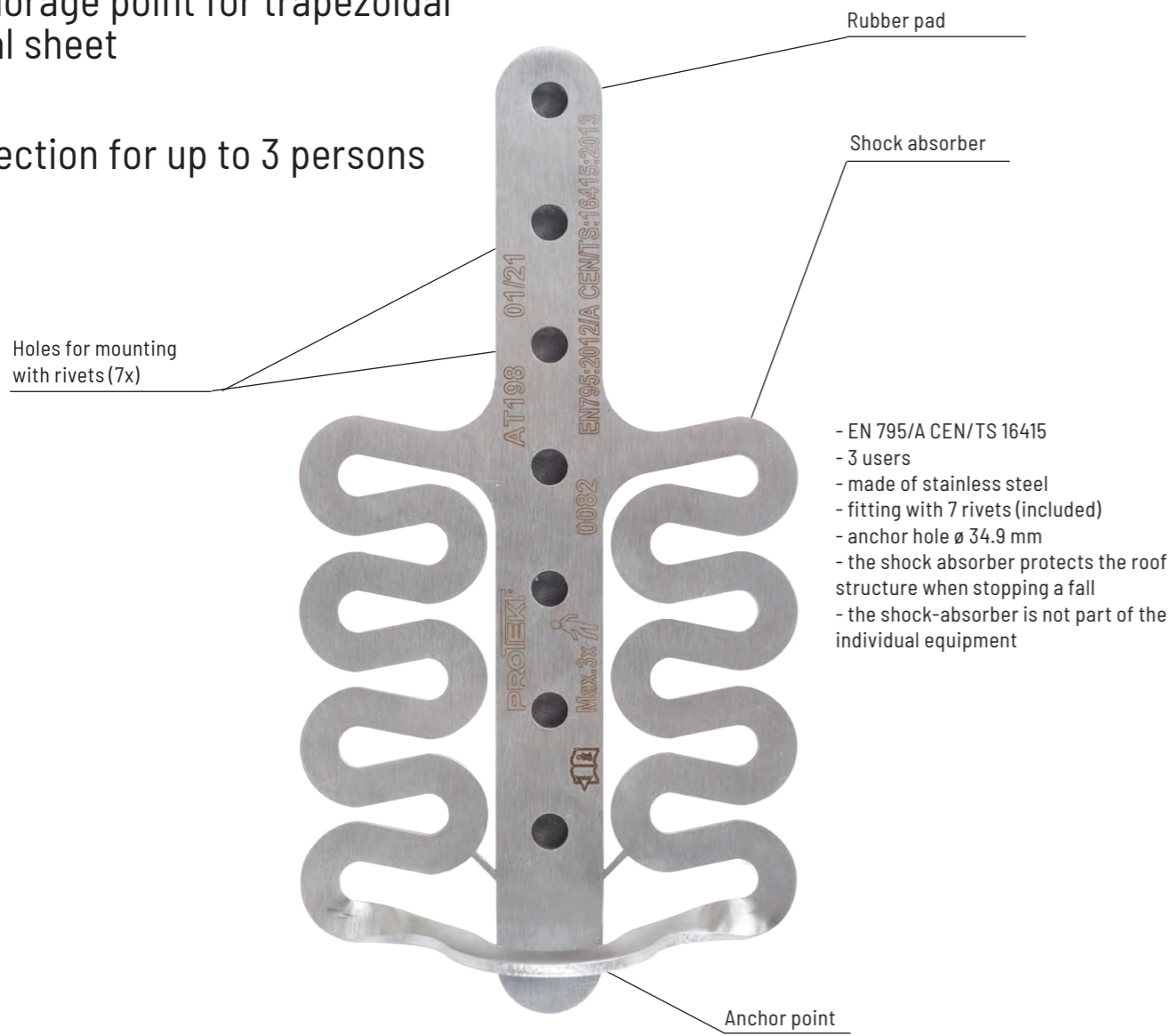

- EN 795/A CEN/TS 16415
- 3 users
- made of stainless steel
- fitting with 7 rivets (included)
- anchor hole  $\varnothing$  34.9 mm
- the shock absorber protects the roof structure when stopping a fall
- the shock-absorber is not part of the individual equipment

## Installation

The kit includes an 7 rivets for trapezoidal sheet.



- over 0.5 mm for steel sheet
- over 0.7 mm for aluminum sheet

## Installation kit

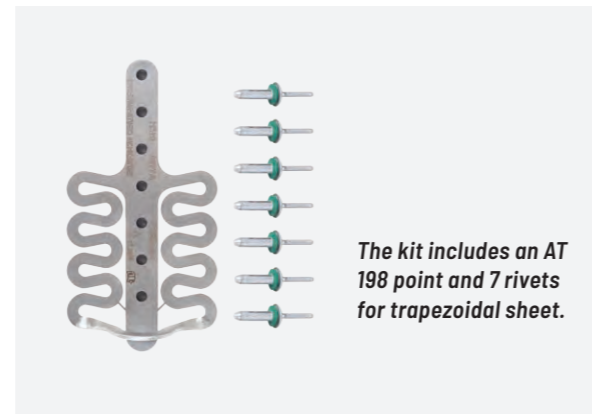

The kit includes an AT 198 point and 7 rivets for trapezoidal sheet.

## Mounting to metal sheet

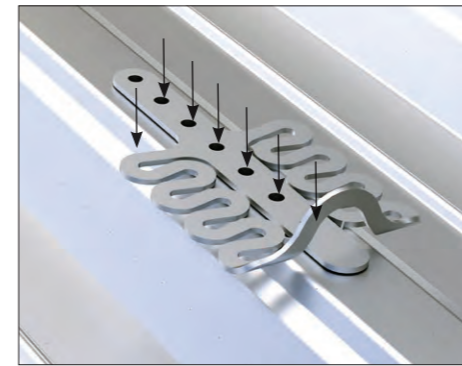

1. Place the point on the trapezoidal sheet in the upper „wave” of the sheet and using a drilling machine make 7  $\varnothing$ 8mm holes, drilling through the mounting holes in the point.



2. Then insert 7 rivets through the mounting holes at the anchor point and the holes made in the trapezoidal sheet.



3. Rivet the rivets using a riveting tool.

## Dimensions

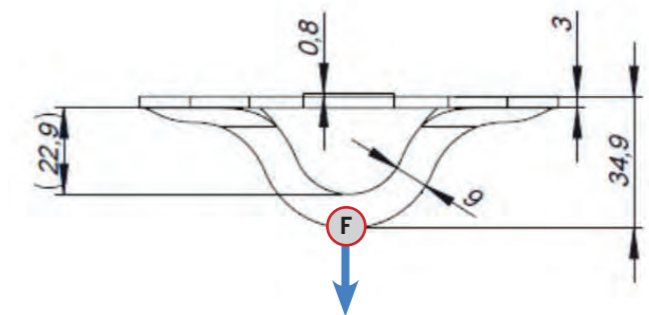
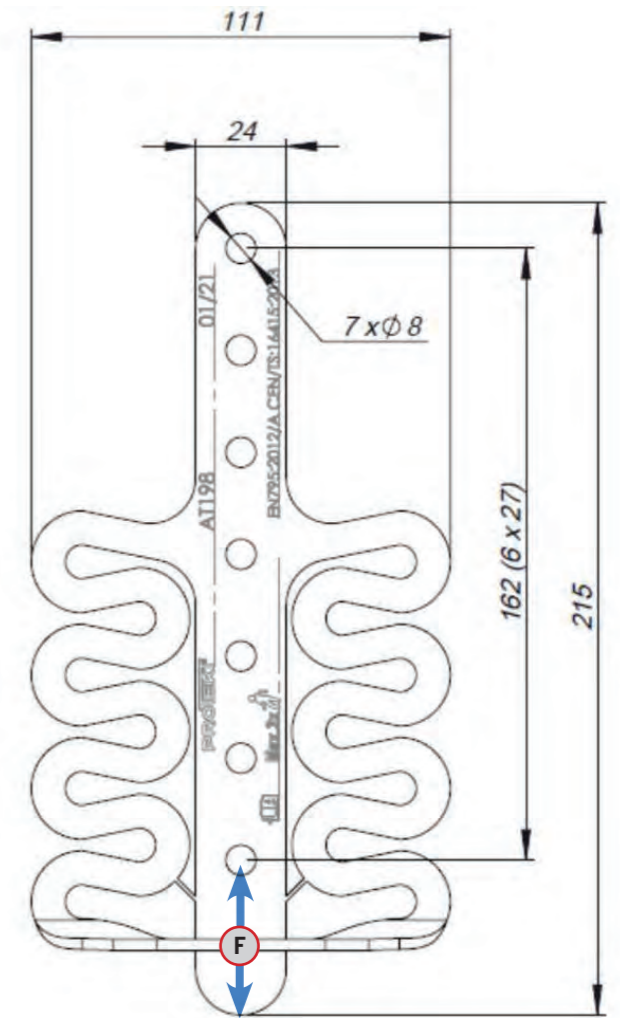

Material:	Stainless steel
Strength:	14 kN
Number of users:	max 3 persons



Protection for max 3 users

# Anchor posts

Anchor points

## HL 700

EN 795/A, CEN/TS 16415:2013

Anchor post for trapezoidal sheet metal.  
Protection for up to 3 persons.

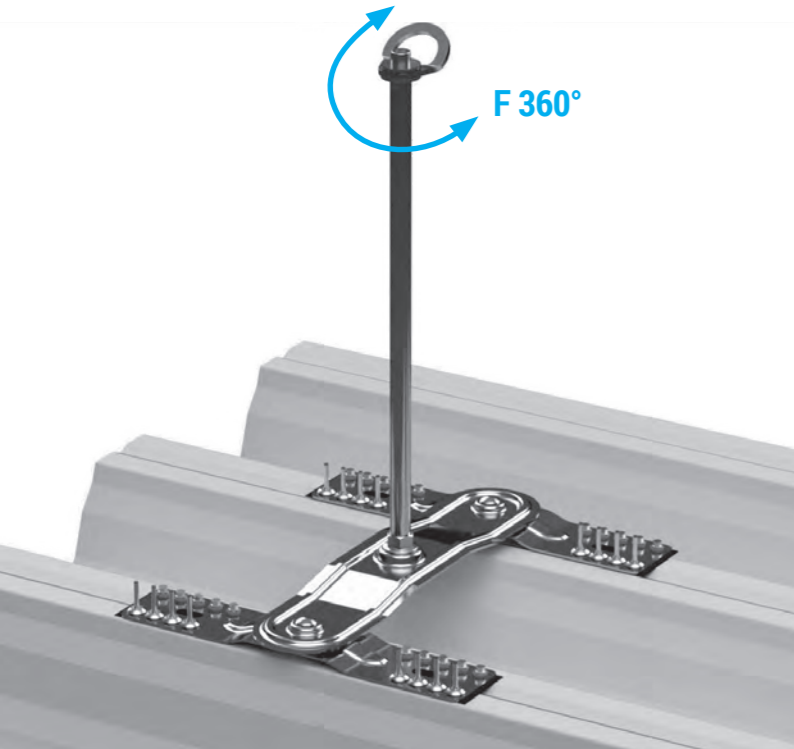

Material	stainless steel
Dimensions	513 x 415 x 375 mm
Bore diameter of the catch point Ø	45 mm
Spacing max.	340 mm



Protection for max 3 users

### Dimensions

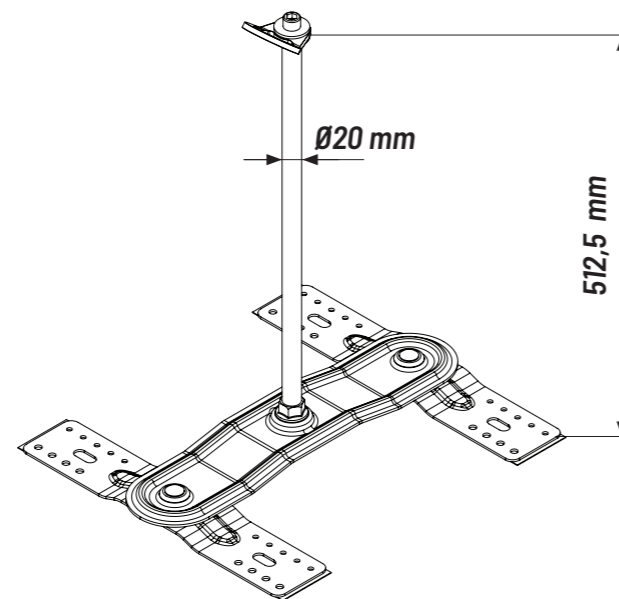
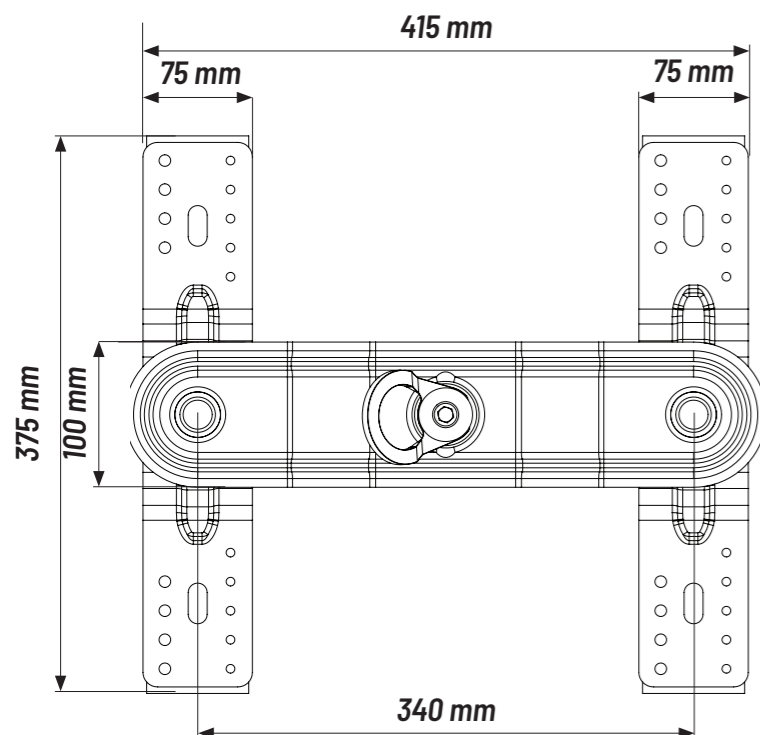

# Anchor posts

Anchor points

NR KAT.: HL 700 102

## FOR SHEET METAL 0,5 - 0,63 MM

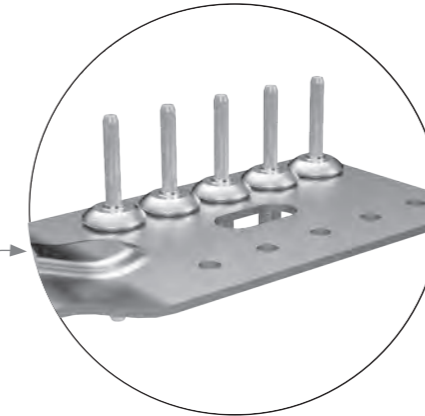
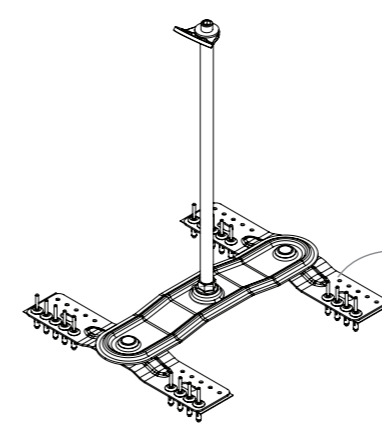

- THE SET INCLUDES:**
- x2 locking bolt M8x20
  - x1 anchor rod
  - x1 fixed plate
  - x2 swivel plate
  - x1 anchor point
  - x16 8 mm blind rivet



NR KAT.: HL 700 101

## FOR SHEET METAL THICKER THAN 0.63 MM

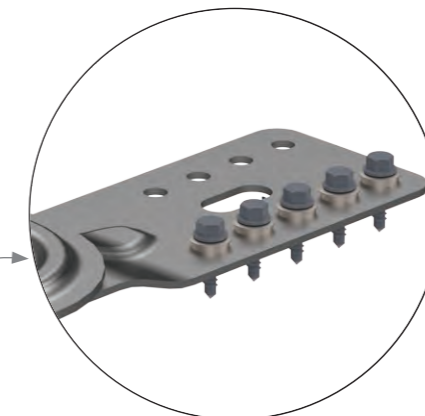
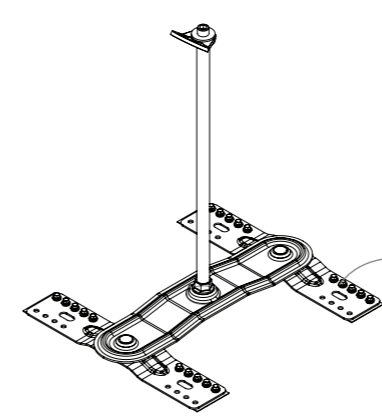

- THE SET INCLUDES:**
- x2 locking screw M8x20
  - x20 sealing screw 5.5x25
  - x1 anchor rod
  - x1 fixed plate
  - x2 pivot plate
  - x1 anchor point

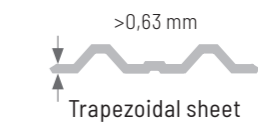

NR KAT.: HL 700 103

## FOR CONCRETE

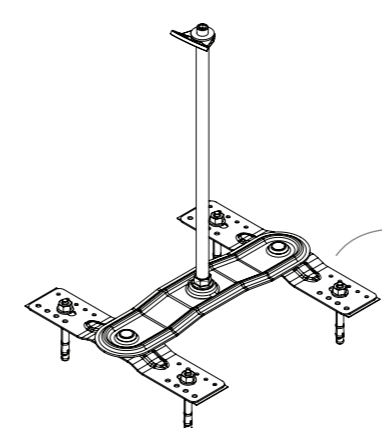

- THE SET INCLUDES:**
- x2 locking screw M8x20
  - x1 anchor rod
  - x1 fixed plate
  - x2 swivel plate
  - x1 anchor point
  - x4 mechanical anchor  
HILTI HST2 M12x115/8 mm

HST2 M12x115/20



Concrete



# Anchor posts

Anchor points

## HLB 700

EN 795/A, CEN/TS 16415:2013

Universal anchor post.

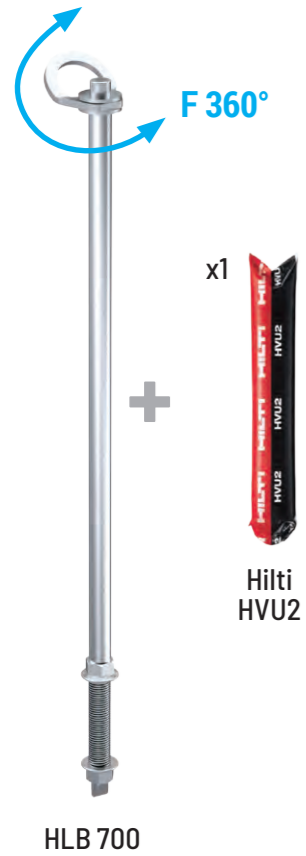

### Mounting

#### Assembly for concrete

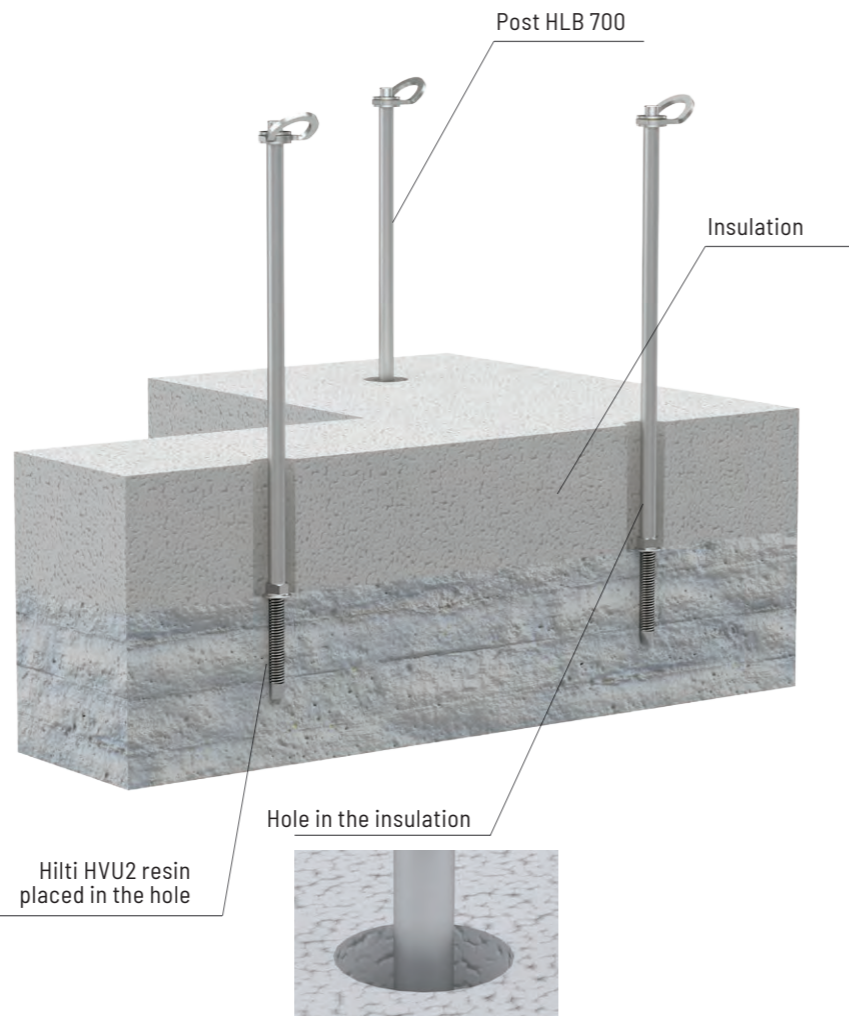

#### Assembly for steel structure

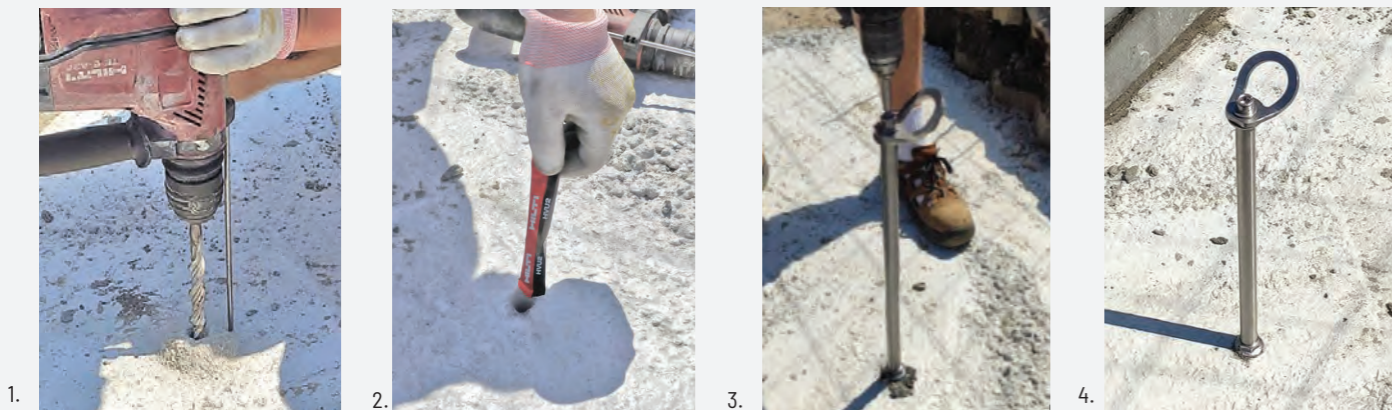
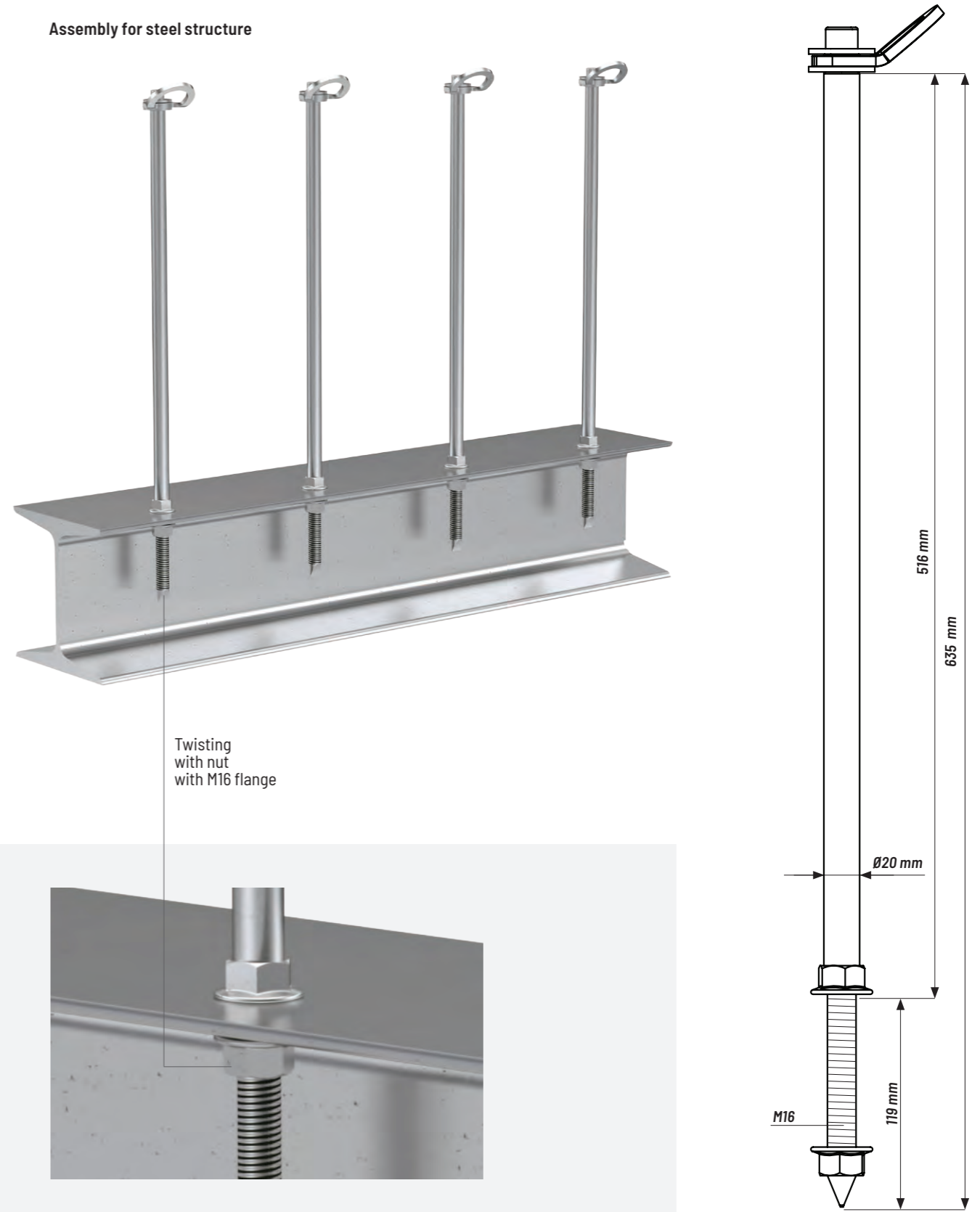

Material	stainless steel
Static strength	14 kN
Bore diameter of the catch point Ø	45 mm
Max. number of users	3

Assembly takes place with a screwdriver by rotating the rod in the chemical resin until it is pressed into the nut itself.



Protection for max 3 users

# Anchor posts

Anchor points

## HLP 700

EN 795/A, CEN/TS 16415:2013

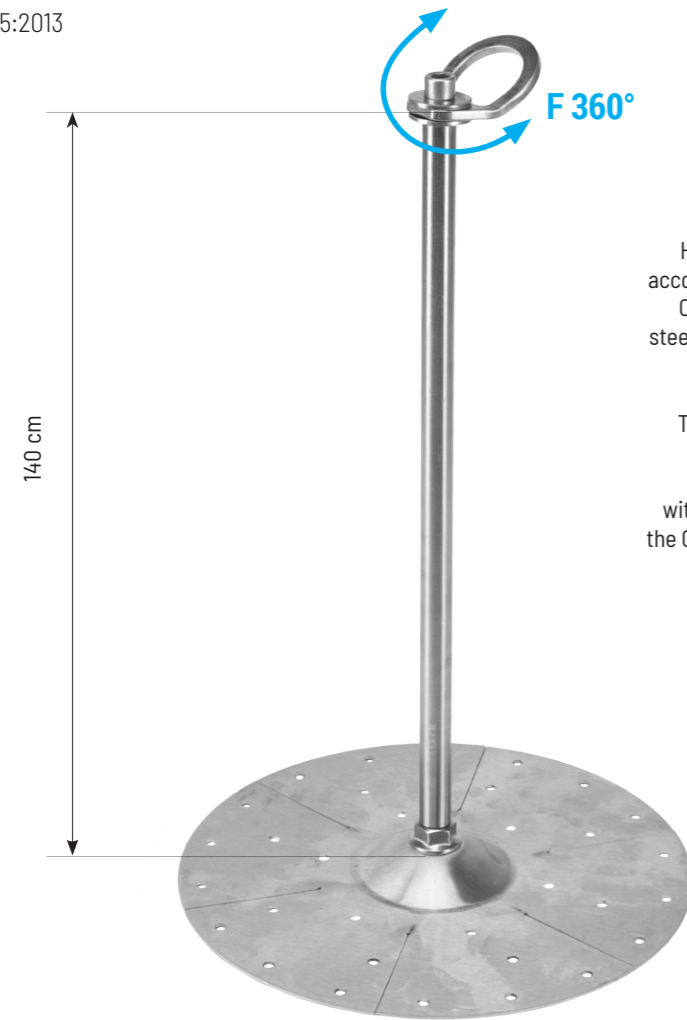

### Universal post belaying post for wood

HLP 700 is an anchor post which is an anchor device according to EN795:2012 type A and CEN/TS/16415:2013. CEN/TS/16415:2013 The HLP 700 is made of stainless steel and is designed for 3 users working simultaneously, with a static strength of min. 14 kN.

The post is designed to be fixed to OSB panels with a thickness of min. 12 mm by means of screws JT3-ST-2-6,0 x 35 HLP 700 is according to with the Regulation of the European Parliament and of the Council (EU) of 9 March 2016 on protective measures 2016/425.

### Mounting

#### Anchor point



#### SET CONTAINS:

- y x32 JT3-ST-2-6,0 x 35
- y x1 Rotating anchor point
- y x1 Post top plate

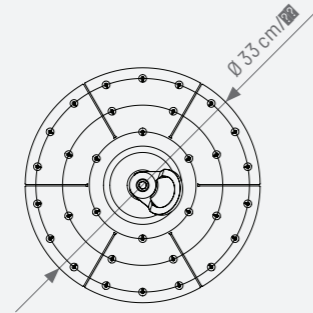

Mounting  
on the plate OSB

Material	stainless steel
Dimensions	500 x 330 x 330 mm
Static strength	14 kN
Bore diameter of the catch point Ø	45 mm
Max. number of users	3



Protection for  
max 3 users

## HLH 700

EN 795/A, CEN/TS 16415:2013

### Universal anchor post for trapezoidal sheet metal

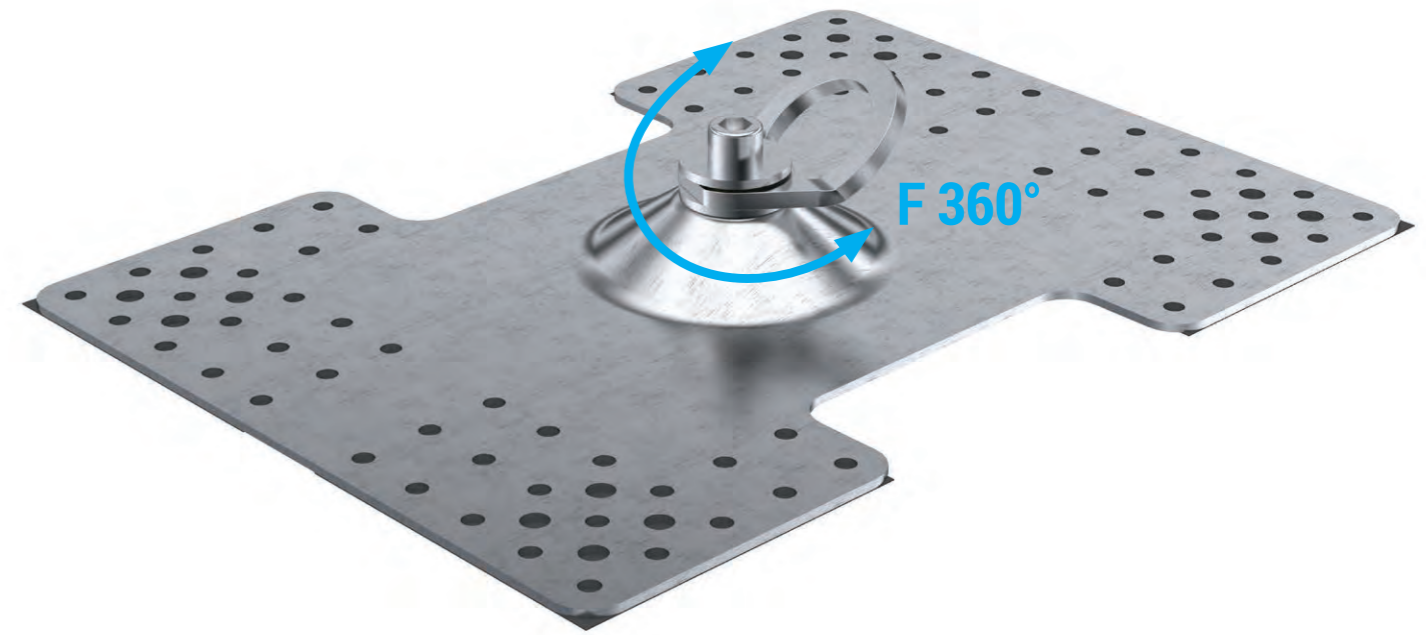

### Versions

#### Anchor point

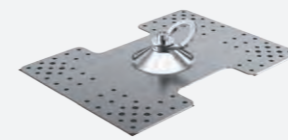

#### SET CONTAINS:

- y x1 Rotating anchor point
- y x1 Post top plate

#### Assembly kit for sheet thicker than 0,63 mm



#### SET CONTAINS:

- y x20 Screw with seal 5,5x25 mm
- y x1 Rotating anchor point
- y x1 Post top plate

#### Assembly kit for sheet thicker than 0,5 mm



#### SET CONTAINS:

- y x8 Tight blind rivet 7 mm
- y x1 Rotating anchor point
- y x1 Post top plate

Material	stainless steel
Dimensions	375 x 275 mm
Static strength	30 kN
Bore diameter of the catch point Ø	45 mm
Max. number of users	3



Protection for  
max 3 users

# Anchor posts PROTON

Anchor points



**PROTON 1**



**PROTON 5**

PROTON 1 and PROTON 5 are rigid posts made of hot-dip galvanized steel, equipped with a swivel plate with three points for connection of personal fall protection equipment. Designed for 3 co-users.

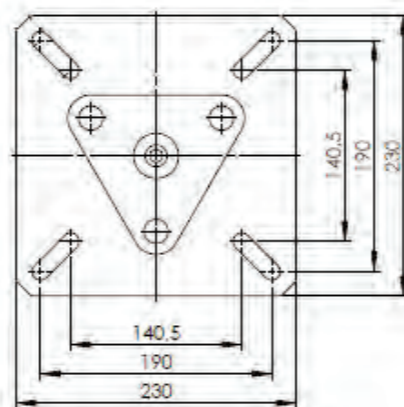
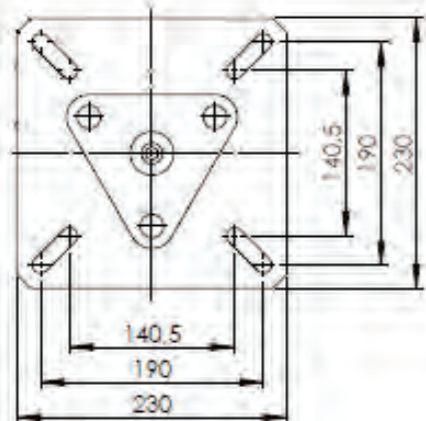
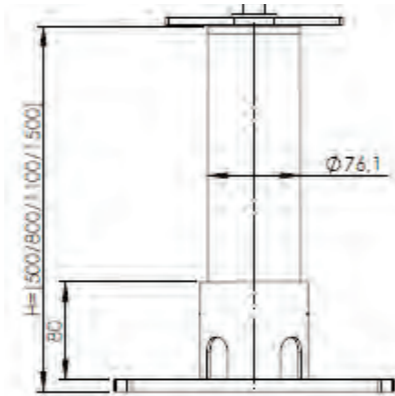
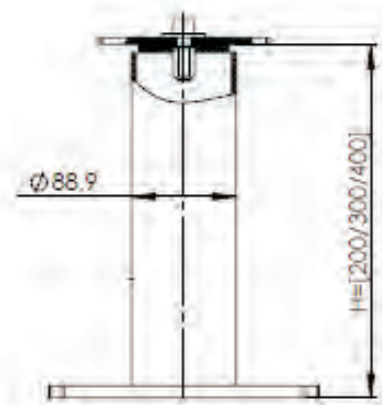

# PROTON 1 and PROTON 5 Installation examples

Anchor points

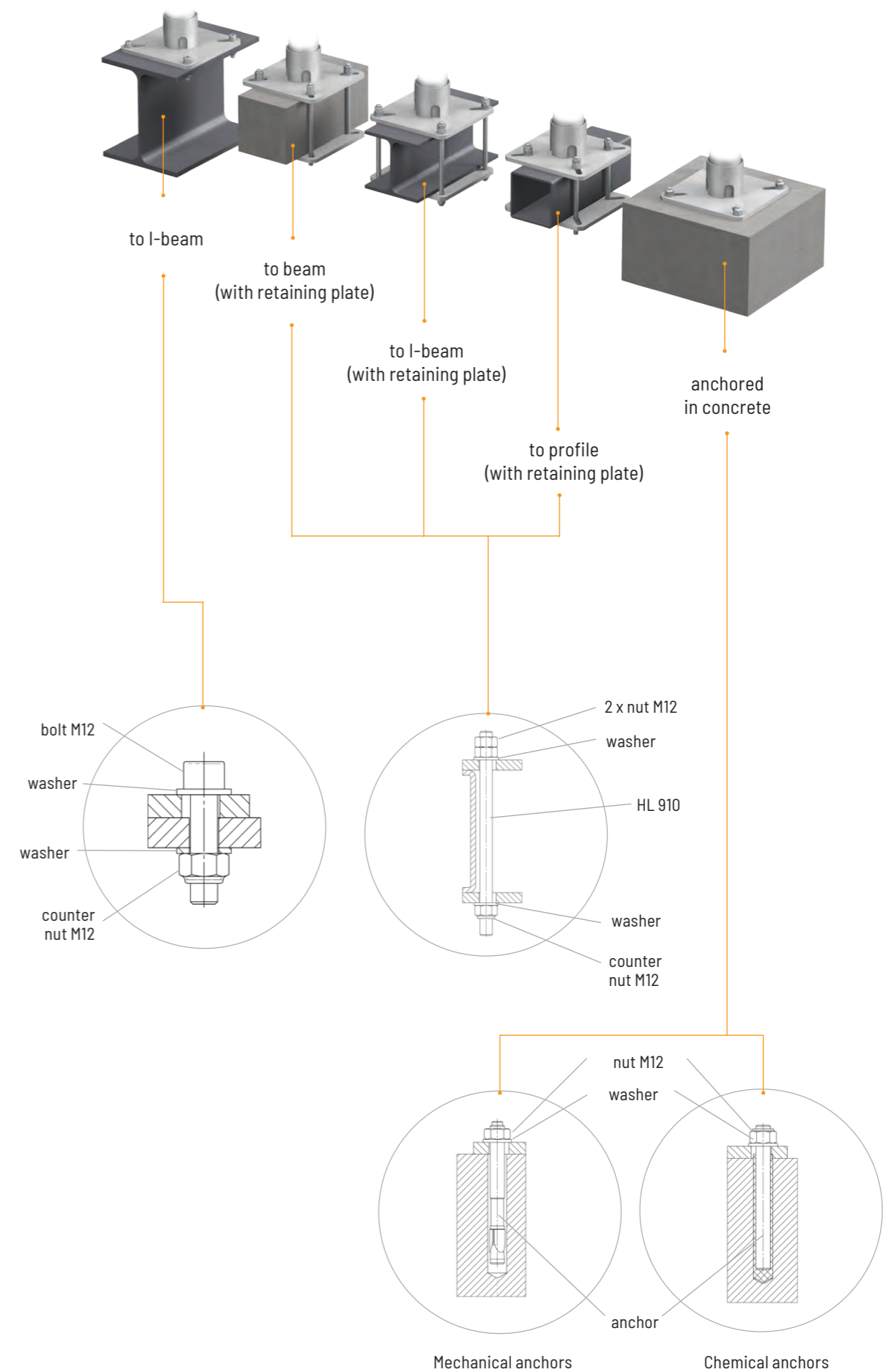

# Anchor points. Anchor posts PROTON

## Anchor points

EN 795/A, CEN/TS 16415:2013

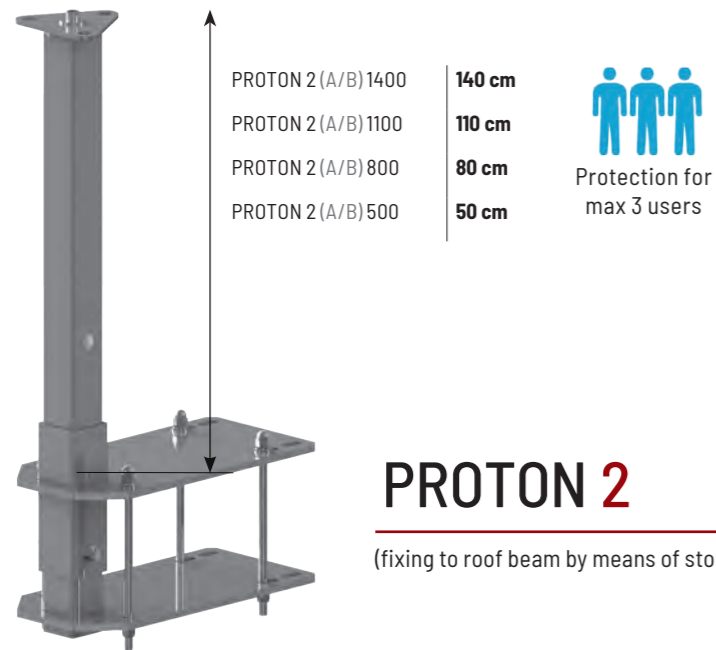

## PROTON 2

(fixing to roof beam by means of stop plates)

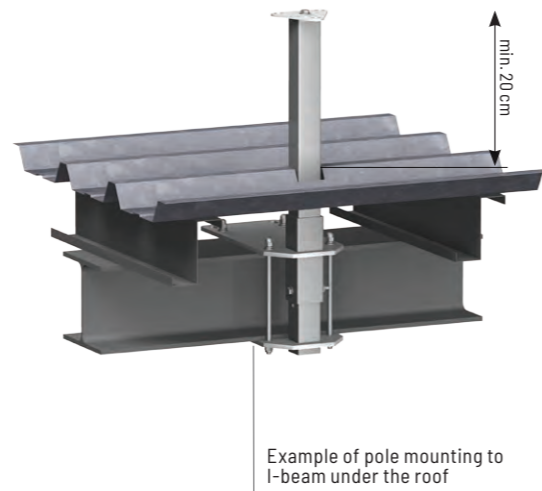

PROTON 2 is a rigid post made of hot-dip galvanized steel, equipped with a swivel plate with three points for connection of personal fall protection equipment. Designed for 3 co-users. PROTON 2 allows for a special method of mounting to a roof beam side.

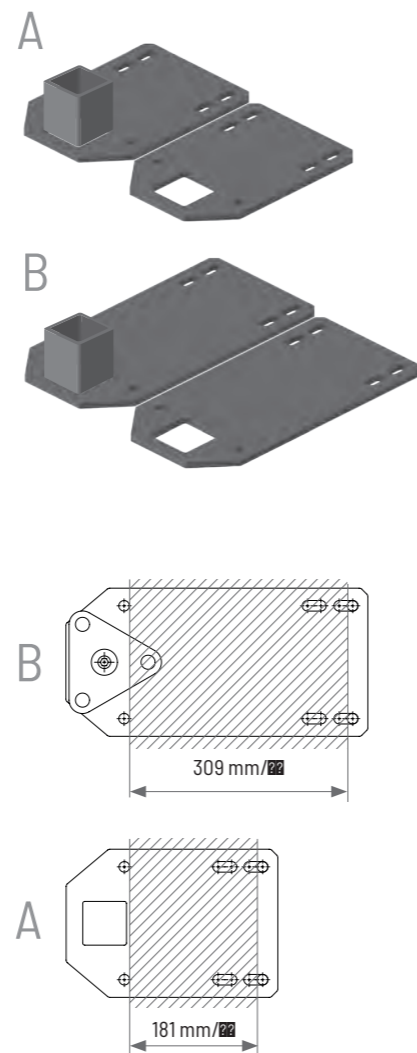
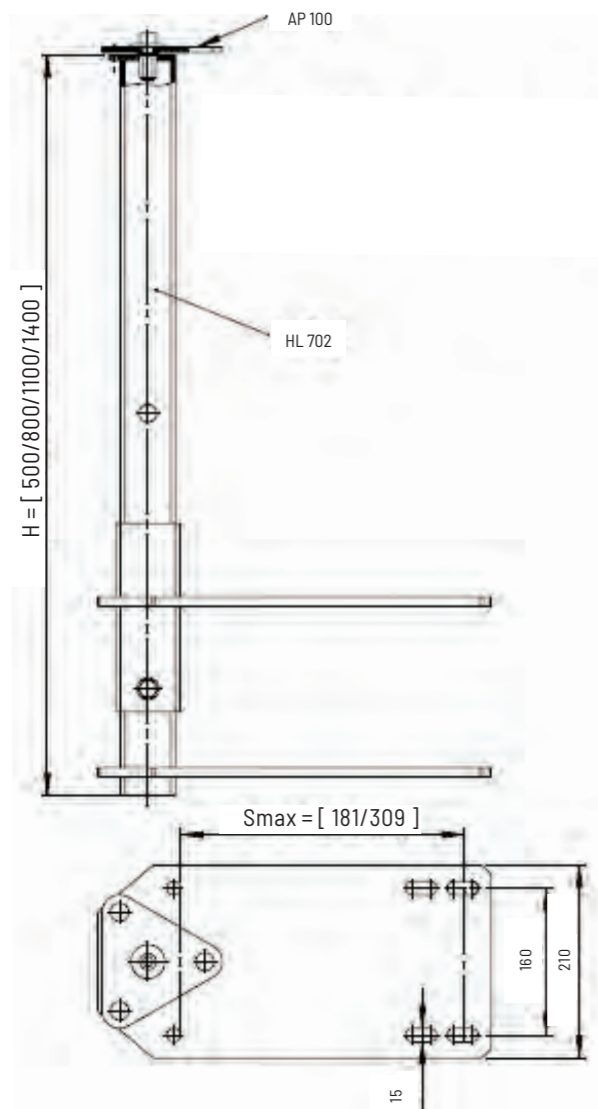

# Anchor posts PROTON

## Anchor points

## PROTON 4

(fixing to trapezoidal sheet metal)



Protection for max 3 users

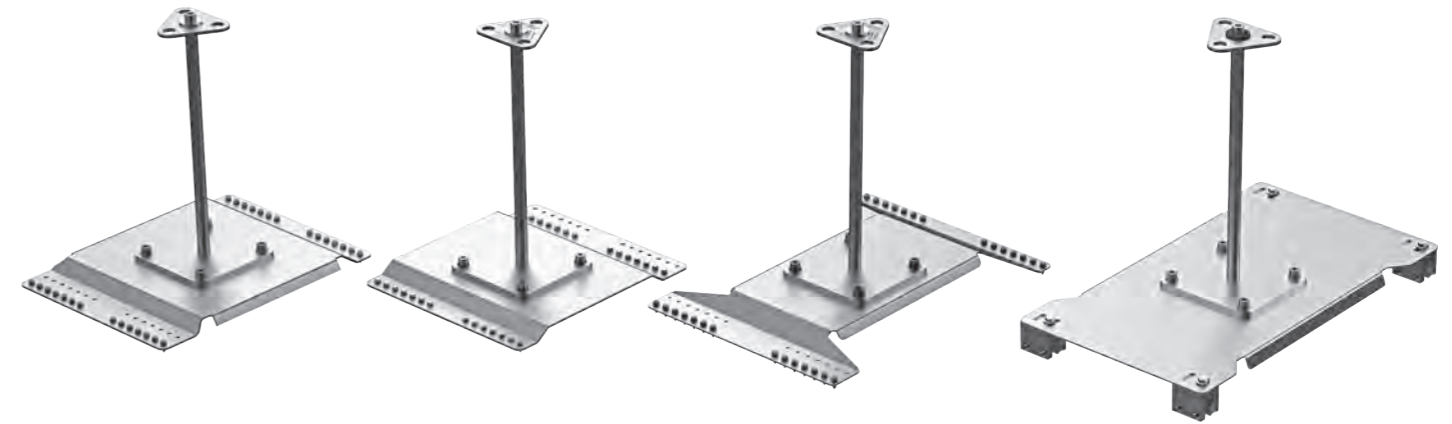
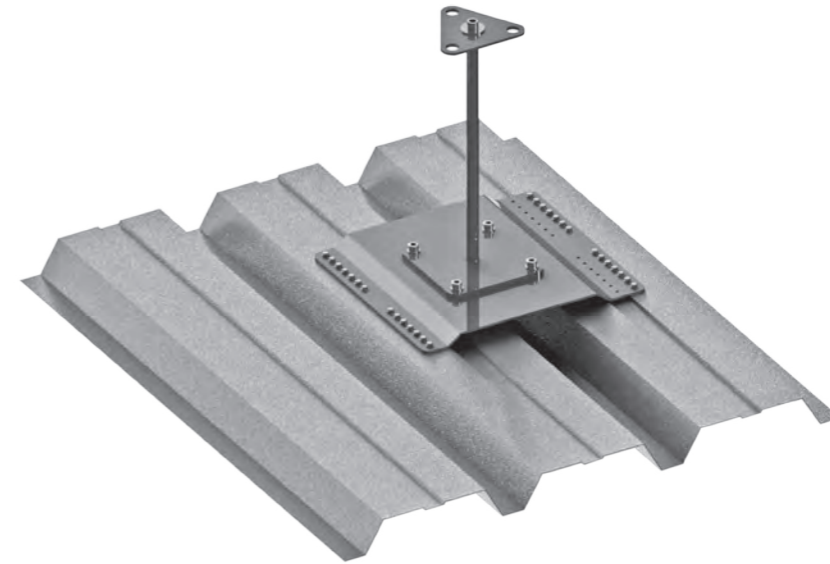

PROTON 4A

PROTON 4B

PROTON 4C

PROTON 4D

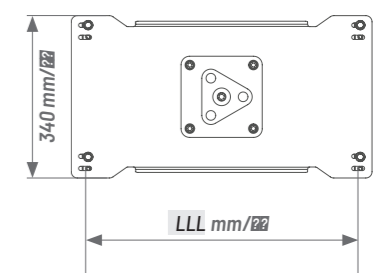
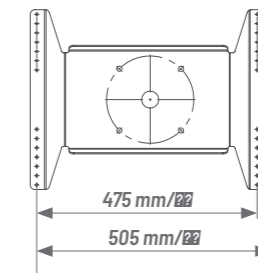
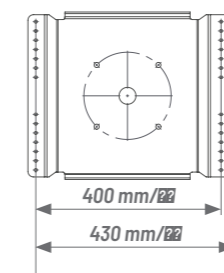
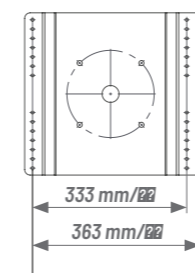

PROTON 4 is an anchor post made of stainless steel, equipped with a swivel plate with three points for connection of personal fall protection equipment. Designed for 3 users. PROTON 4 allows for installation directly to steel sheet roofing, if the sheet is an outer cover, and also if covered with an insulation material. With various configurations of the post the product can be used for a wide range of metal sheet profiles, and also standing seam roofing.

Table of compatibility of PROTON 4 post variants and types of trapezoidal sheet

Type of trapezoidal sheet	Sheet position	Type of post suitable for sheet	Type of trapezoidal sheet	Sheet position	Type of post suitable for sheet
Hacierco 40/160	Positive	A	HACIERCO 94/255	Positive	A
		C			B
	Negative	A		C	
Hacierco 40/183	Positive	A	HACIERCO 135/135	Positive	A
		B			B
		C			Negative
Hacierco 50/265	Positive	C	HACIERCO 136/310	Positive	A
		C			B
	Negative	C		Negative	A
Hacierco 50/260	Positive	A	HACIERCO 145/280	Positive	A
		C			C
	Negative	C		Negative	A
HACIERCO 60/235	Positive	A	HACIERCO 150/280	Positive	A
		C			C
	Negative	C		Negative	n/a
HACIERCO 70/200	Positive	A	HACIERCO 160/250	Positive	A
		B			C
	Negative			Negative	C
HACIERCO 80/280	Positive	B	HACIERCO 160/260N	Positive	A
		A			C
	C	Negative		C	
HACIERCO 84/273	Positive	A	HACIERCO 200/420-2T	Positive	A
		C			B
	Negative	Brak rozwiązania		Negative	B
HACIERCO 90/262,5	Positive	A			
		C			
	Negative	C			
HACIERCO 94/305	Positive	A			
	Negative	A			

Type of trapezoidal sheet	Sheet position	Type of post suitable for sheet	Type of trapezoidal sheet	Sheet position	Type of post suitable for sheet
T50P	Positive	A	T92P	Positive	B
	Negative	C		Negative	A
T55P	Positive	A	T130	Positive	A
		B		B	
	Negative	C		Negative	A
T60P	Positive	C	T135P	Positive	A
	Negative	C		Negative	A
T80	Positive	A	T150	Positive	A
		C		Negative	A
	Negative	A		Positive	A
T92P	Positive	A	T160	Positive	A
		C			C
	Negative			Negative	C

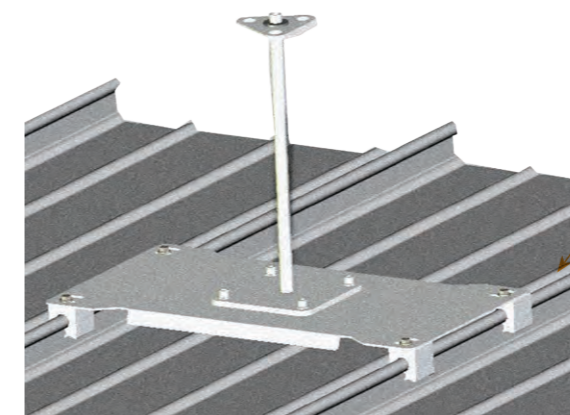

### PROTON 4 (mounting to standing seam)

S5\_ - types of clamps depending on the type of seam

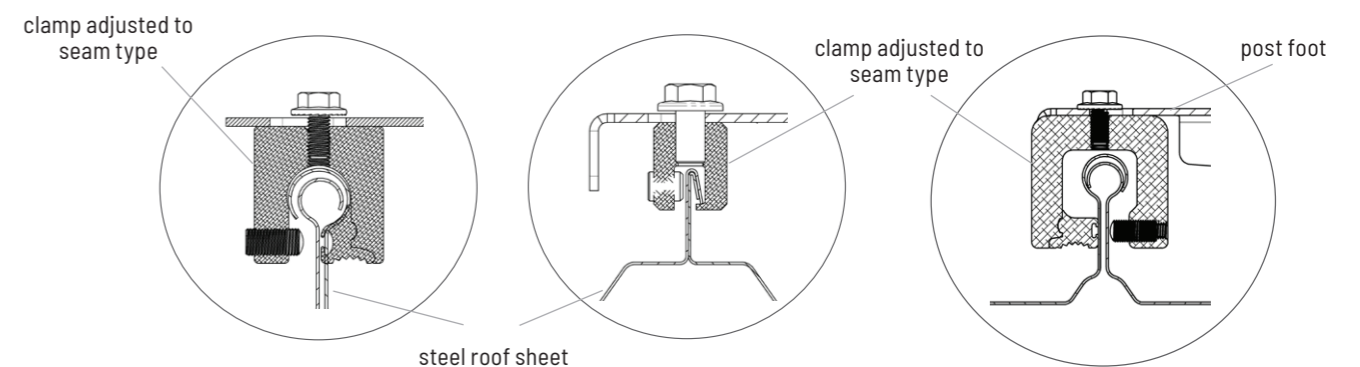



## Line systems Design parameters

### Line systems

For horizontal lifelines, two design parameters are defined - forces loading system mountings to load-bearing structure (intermediate and final structural anchor points)  $F_k$  and  $F_p$  and line deflection  $D$  (Fig.).

These parameters depend on:

- system geometry, i.e. total length -  $L$  and distance between intermediate mountings -  $S$
- expected load of the system when arresting a fall, resulting from the number of co-users of the system -  $N$
- characteristics (force - deformation) of the system components which determine its susceptibility (formability) under a load.

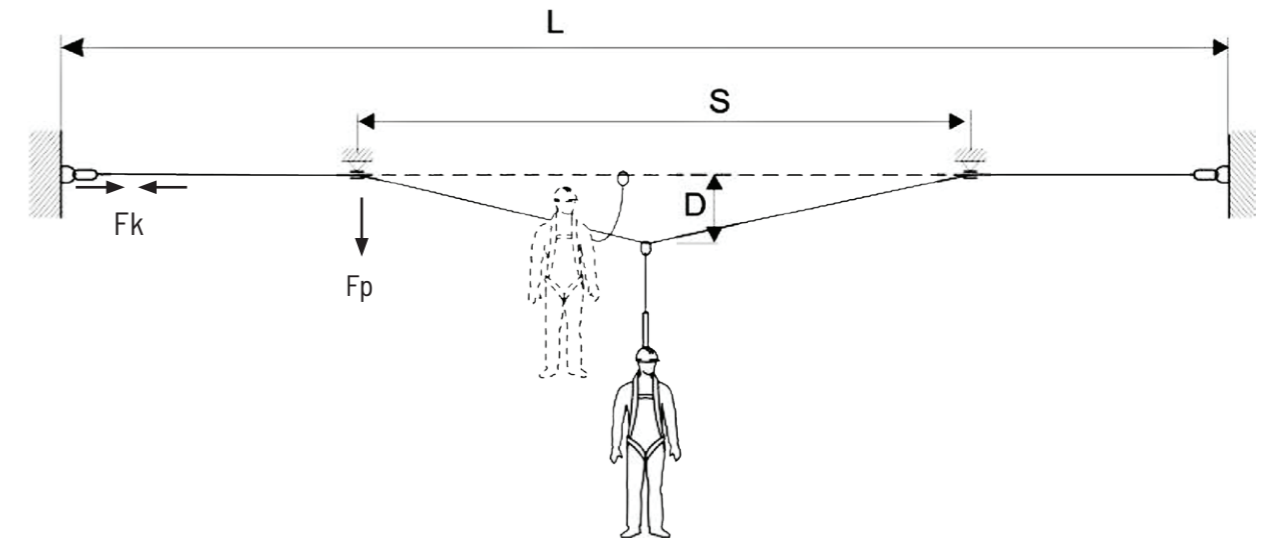

Strength of load-bearing structure and system mountings to load-bearing structure should meet the following conditions:

$$R_k \geq 2 \times F_k$$

$$R_p \geq 2 \times F_p$$

Values  $F_k$ ,  $F_p$  and  $D$  are determined theoretically and verified through laboratory testing or only experimentally within laboratory testing. Example values  $F_k$ ,  $F_p$  and  $D$  are given in pages presenting particular products. For designing of functional systems, to determine forces " $F_k$ " and " $F_p$ " and deflections " $D$ " specialised software dedicated specially for PROTEKT products, is used.

Dialog box of software used to determine forces and deflections in **line anchorage system**

PRIM Horizontal Anchorage System Data Sheet

Date: \_\_\_\_\_  
 Client: \_\_\_\_\_  
 Project: \_\_\_\_\_

FIELDS for selection and input data

End Structural Anchor     Cable Stretcher     Energy Absorber     Intermediate Structural Anchor

Total System Length -  $L$   
 Max. Intermediate Span -  $S_{max}$

$F$  [kN] - End Structural Anchor's Load (The force acting into rope)  
 $F_p$  [kN] - Intermediate Structural Anchor's Load  
 $D$  [m] - Maximal deflection of the system's cable during fall arresting

Input Data - variables	
Total System Length - $L$	20.0 [m]
Maximal Intermediate Span - $S$	19.0 [m]
Number of co-users - $N$	2 [person(s)]

Input Data - constants	
Maximal Fall Load	6.0 [kN]
Initial tension of the system cable	0.8 [kN]

Output Data	
End anchor's load - " $F$ "	17.2 [kN]
The required durability " $R$ " of the extremity fastenings $R=2 \times F$	34.4 [kN]
Intermediate structural anchor's load - " $F_p$ "	6.0 [kN]
The required durability " $R_p$ " of the intermediate structural fastenings $R_p=2 \times F_p$	12.0 [kN]
Deflection " $D$ " of the cable during fall arresting	1.2 [m]

# PRIM Horizontal anchor system with anchor line



7 MAXIMUM USERS

Line anchor system PRIM is a C class anchor device conforming to EN 795 and CEN / TS16415. The system is designed for use by a group of up to 3 users at the same time, and can be re-configured to provide protection for a larger group of up to 7 users. It can be installed on building walls, structures and on roofs or terraces, etc. It comprises the following types of components

- end structural anchor elements such as end plates or posts;
- intermediate structural mounting elements such as line holders or line return rolls;
- energy absorbers and line tensioning elements;
- connecting elements;
- line being a guide for mobile anchor points.

The system is made of stainless steel (cable, energy absorbing and connecting components) or galvanized steel (selected fastening elements). It is equipped with end and intermediate anchor points of anchor line and fall arrester which reduce loads transferred on the structure.



Stainless-steel two-point mounting plate. For mounting line ends. Recommended for steel or strong concrete surfaces.

HL101



Stainless-steel three-point mounting plate. For mounting line ends. Can be used on any surface type.

HL102



Intermediate line holder. Made of stainless steel.

H202

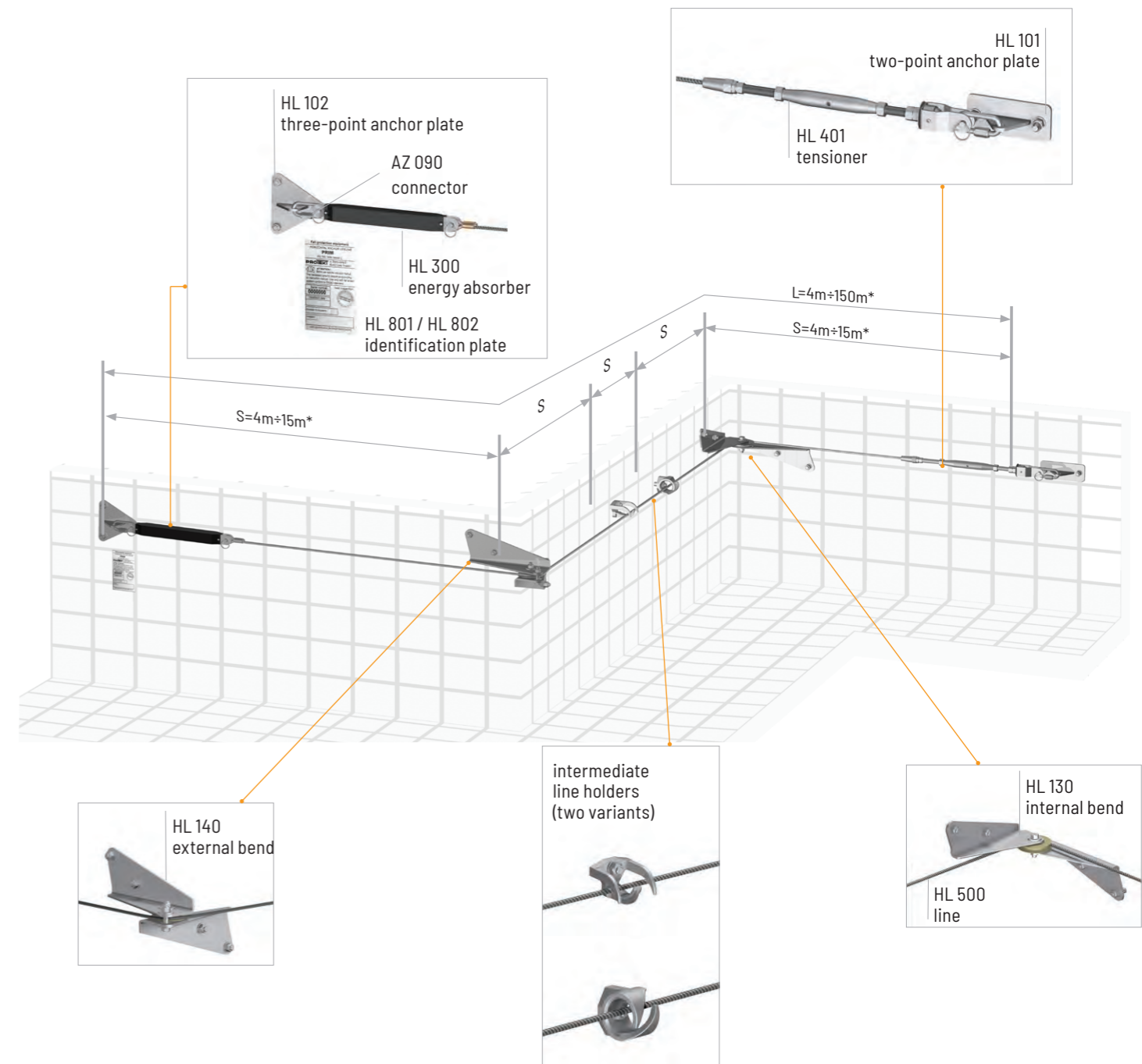

Values of force F transferred on lifeline [kN]\*

Total length of system [m]	15	50	100
Span length [m] 5	11,3	9,3	7,8
Span length [m] 15	15,3	11,5	9,8

Values of deflection D of lifeline [m]\*

Total length of system [m]	15	50	100
Span length [m] 5	0,5	0,5	0,6
Span length [m] 15	1,1	1,1	1,1

\*special solutions may include other length (for more information please contact our representatives). \*\* given indicative values and cannot be used for system design



Post made of hot-dip galvanized steel. Height: 200mm; 300 and 400mm.  
Recommended for terraces and concrete roofs without thermal insulation.

Post type HL 701



Post made of hot-dip galvanized steel. Height: 500mm; 800mm; 1100mm and 1500mm.  
Recommended for terraces and concrete roofs with thermal insulation or temporarily covered with, e.g. snow.

Post type HL 704



Post of 250mm in height, made of stainless steel. Designed for trapezoidal-sheet roofs, mounted with screws or rivets.

Post type HL 760



Post of 250mm in height, made of stainless steel. Designed for roof covered with standing seam sheet metal roofing.

Post type HL 763

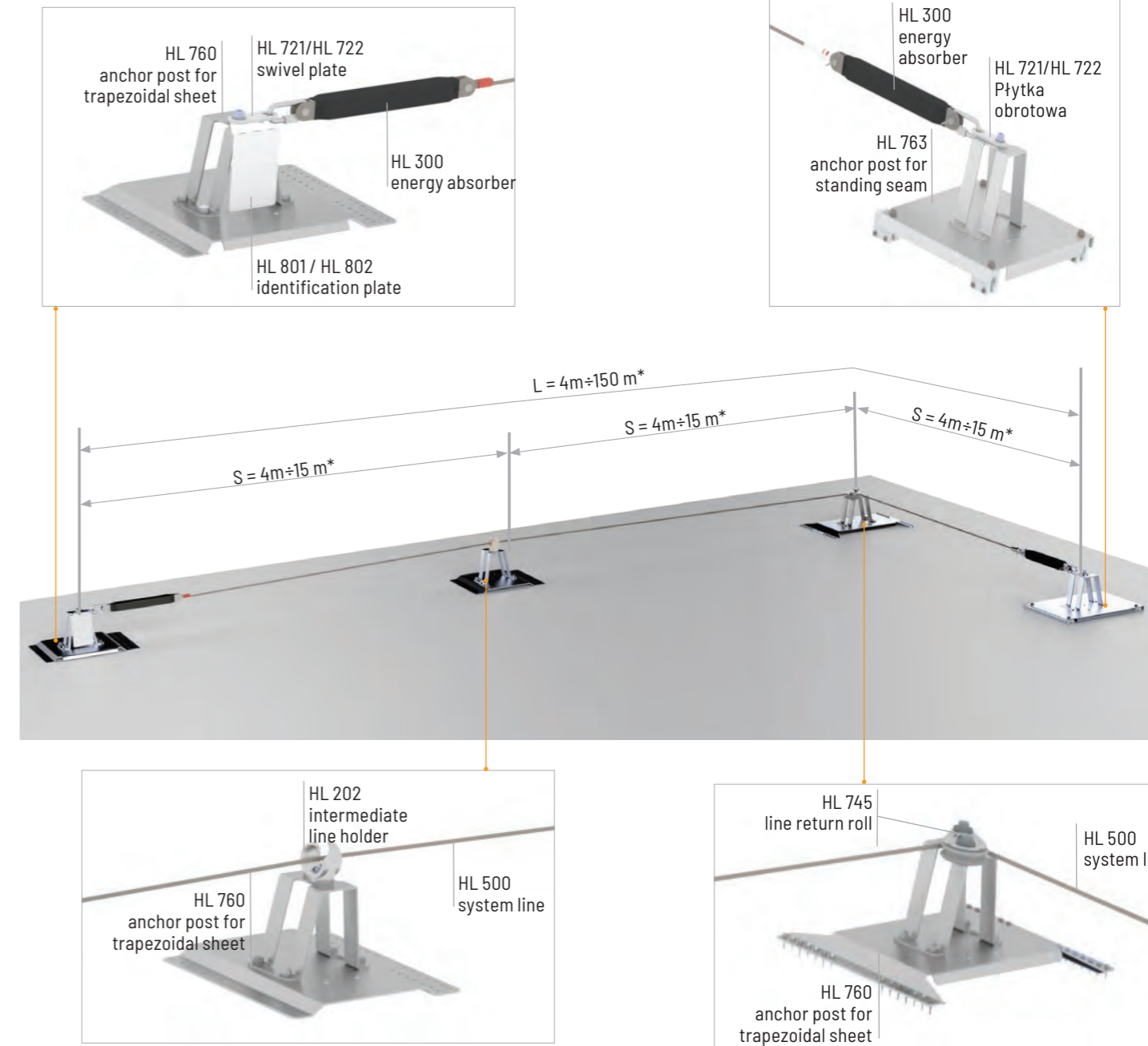
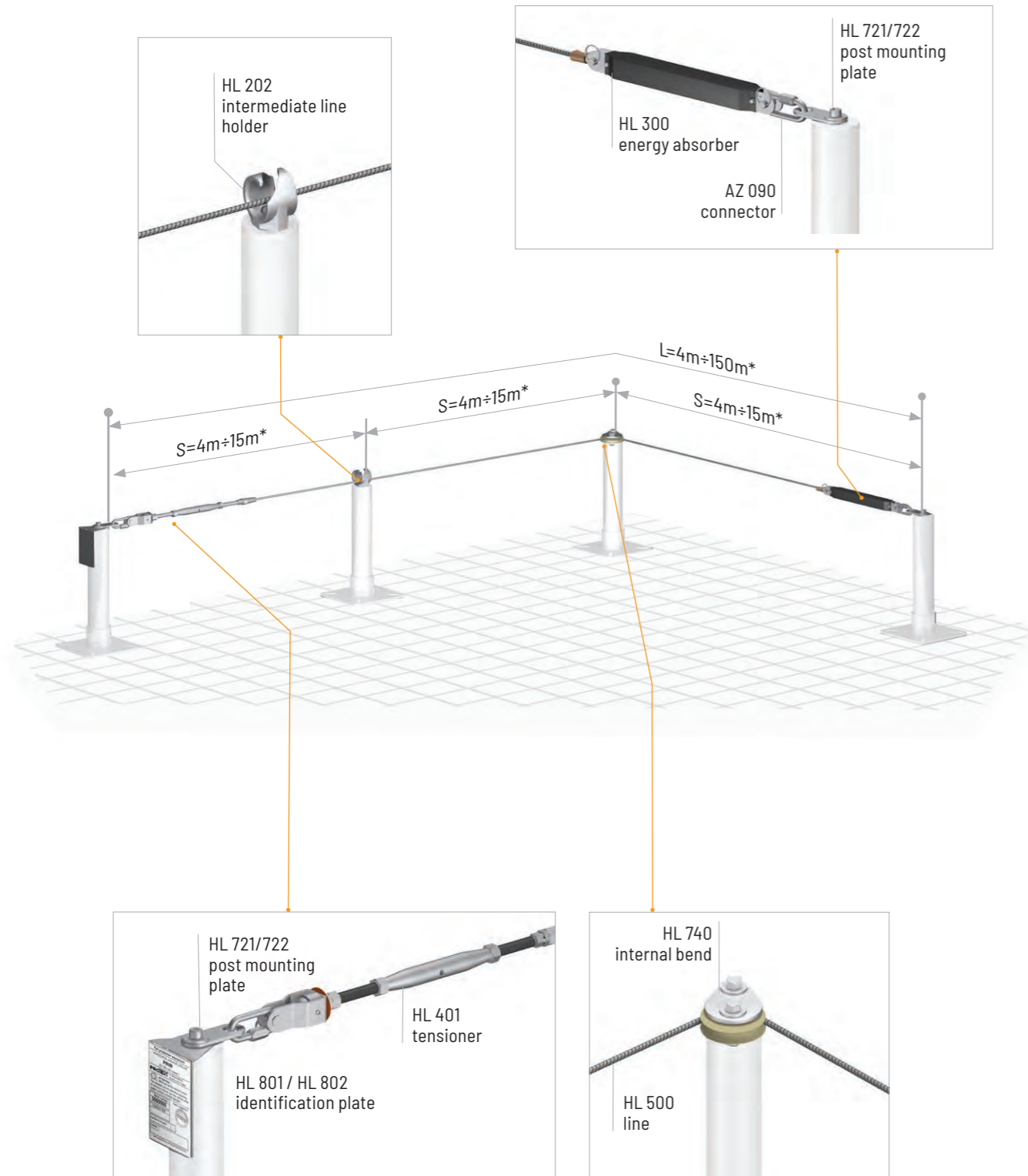

Values of force F transferred on lifeline [kN]\*

Total length of system [m]		15	50	100
Span length [m]	5	9,6	8,4	7,4
	15	11,5	10,3	6,8

Values of deflection D of lifeline [m]\*

Total length of system [m]		15	50	100
Span length [m]	5	0,6	0,6	9,1
	15	1,2	1,2	1,2

\*special solutions may include other length (for more information please contact our representatives). \*\* given indicative values and cannot be used for system design

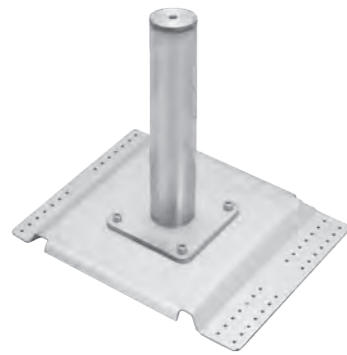

Post type HL 720 of 450mm in height, made of stainless steel. For trapezoidal-sheet roof with thermal insulation or temporarily covered with, e.g. snow. Mounted with screws or rivets.

Post type HL 720



Post type HL 720-S5Z-400 of 450mm in height, made of stainless steel. For standing seam type roofing, temporarily covered with, e.g. snow.

Post type HL 720-S5Z-400

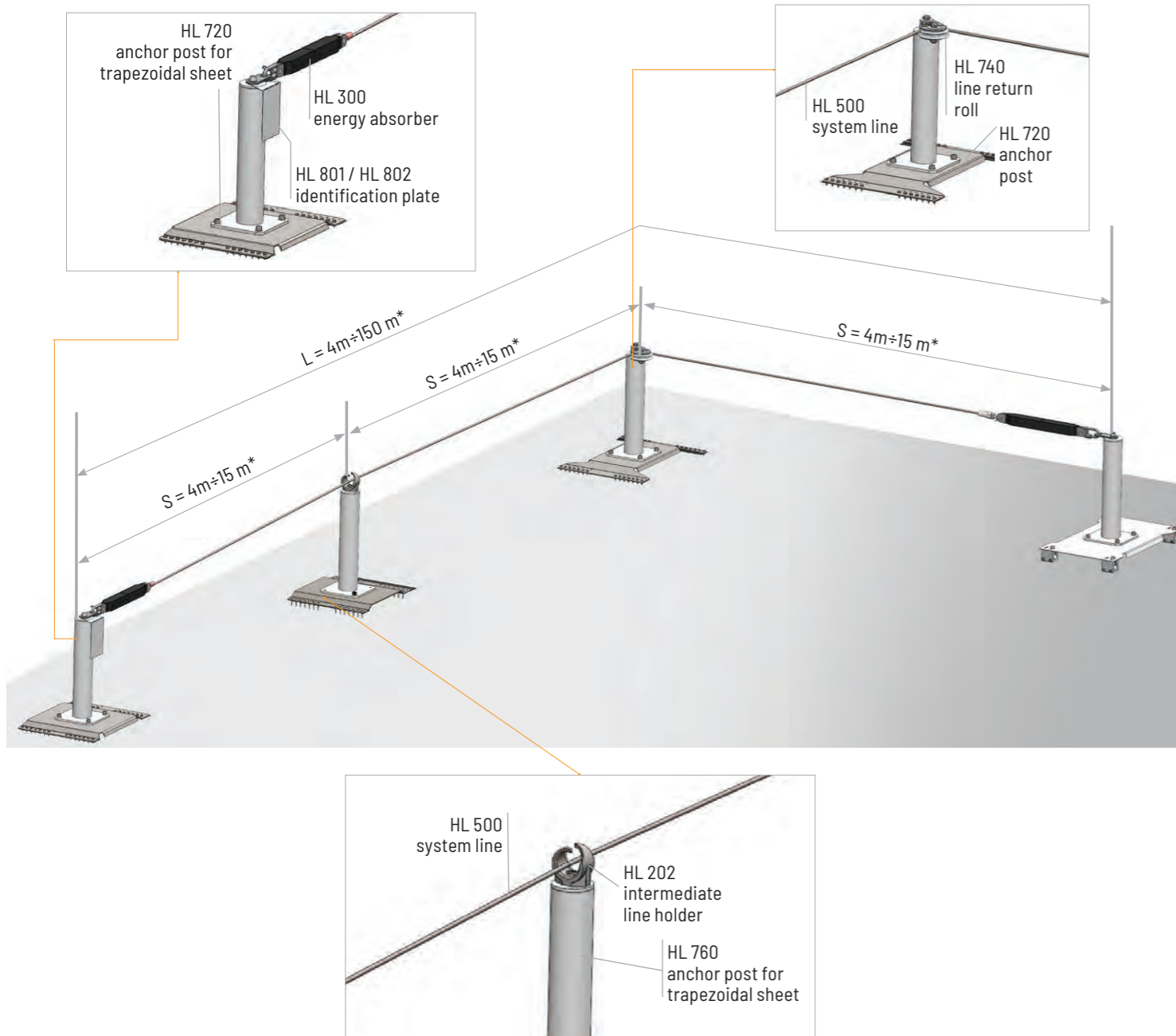

Values of force F transferred on lifeline [kN]\*\*

Total length of system [m]	15	50	100
Span length [m]	5	6,2	5,7
	15	8,2	6,8

Values of deflection D of lifeline [m]\*\*

Total length of system [m]	15	50	100
Span length [m]	5	0,8	0,8
	15	1,6	1,6























\*special solutions may include other length (for more information please contact our representatives). \*\* given indicative values and cannot be used for system design



® Example configuration of system PRIM on a flat roof and a platform.

# PRIM system components

## Line systems

 HL 101 2-point mounting plate	 HL 102 3-point mounting plate	 HL 130 wall return roll (external bend)	 HL 140 wall return roll (internal bend)
 HL 201 intermediate line holder	 HL 202 intermediate line holder	 HL 300 energy absorber	 HL 401 tensioner
 HL 500 lanyard	 HL 501 stainless steel cable ø 8mm	 HL 506 cable clip with opening	 HL 721/722 2-point swivel plate
 HL 740 return roll for pole	 HL 745 return roll for pole	 AZ 090 connector	 HL 801 / HL 802 informative plates (stainless steel / PVC)
 HL 701 pole with central foot	 HL 702 pole with side foot	 HL 704 pole with central foot and flange	 HL 720 A / HL 720 B posts for trapezoidal sheet
 HL 760 A / HL 760 B posts for trapezoidal sheet	 HL 763 post mounted to standing seam	 HL 720-S5Z post mounted to standing seam	



® Example configuration of system PRIM on a flat roof covered with roofing paper.

7 MAXIMUM USERS

Line anchor system DUO is a C class anchor device conforming to EN 795. Designed for use by 1, 2 or 3 co-users, with possible re-configuration for 7 users. The system can be installed on building walls, steel structures or roofs or terraces. The system comprises the following types of components:

- end structural anchor elements such as wall plates or posts;
- intermediate structural mounting elements such as line holders or tube bends;
- energy absorbers of line tensioning elements;
- connecting elements for line being a guide for mobile anchor points for personal fall protection equipment.

Each user is attached to an individual slide being a mobile anchor point for personal fall protection equipment and enabling free mobility along the system without hampering the anchorage.

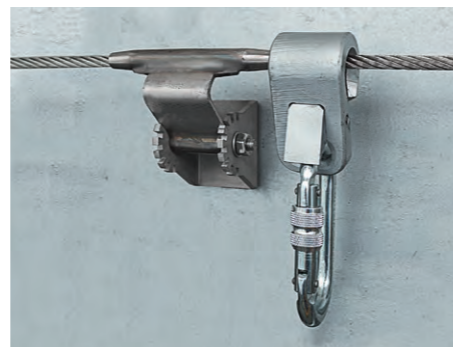
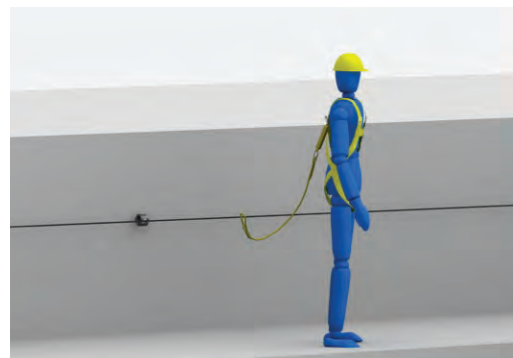

Sequence for travelling the slide, being a mobile anchor point, along the system including pass through a lug without hampering the anchorage.



Stainless-steel mounting plate. For mounting line ends. Can be used on various surface types.

HL 103



Intermediate line holder. Made of stainless steel.

HL 203

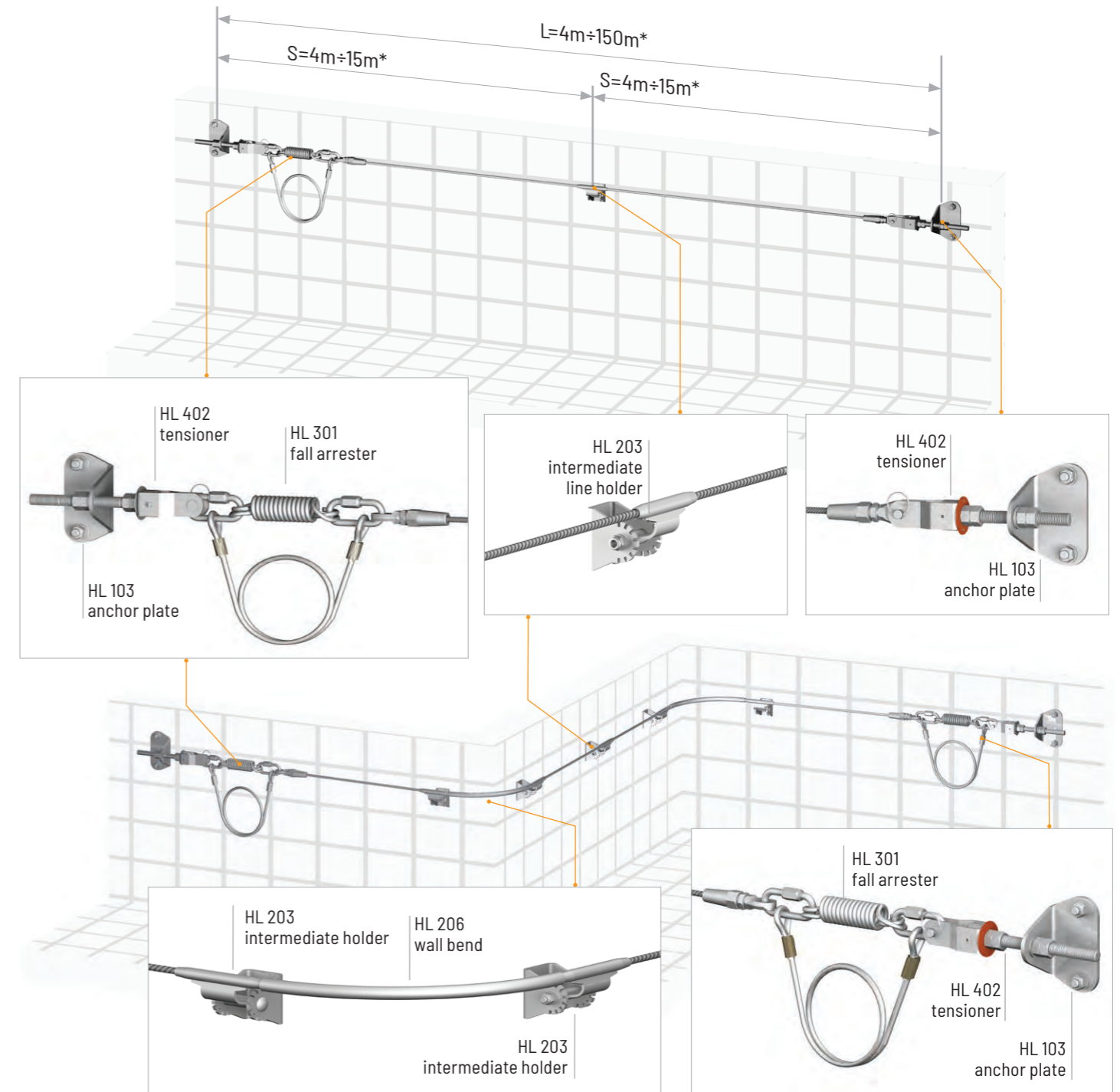

Values of force F transferred on lifeline [kN]\*\*

Total length of system [m]	15	50	100
Span length [m]	5	8,5	8,3
	15	8,2	8,7
			8,5

Values of deflection D of lifeline [m]\*\*

Total length of system [m]	15	50	100
Span length [m]	5	0,7	0,7
	15	1,6	1,4
			1,5

\*special solutions may include other length (for more information please contact our representatives). \*\* given indicative values and cannot be used for system design



Post made of hot-dip galvanized steel. Height: 200mm; 300mm and 400mm.  
Recommended for terraces and concrete roofs without thermal insulation.

Post type HL 701



Post made of hot-dip galvanized steel. Height: 500mm; 800mm; 1100 mm and 1500 mm.  
Recommended for terraces and concrete roofs with thermal insulation or temporarily covered with, e.g. snow.

Post type HL 704



250mm in height, made of stainless steel. Designed for trapezoidal-sheet roofs, mounted with screws or rivets.

Post type HL 760



250mm in height, made of stainless steel. Designed for roof covered with standing seam sheet metal roofing.

Post type HL 763

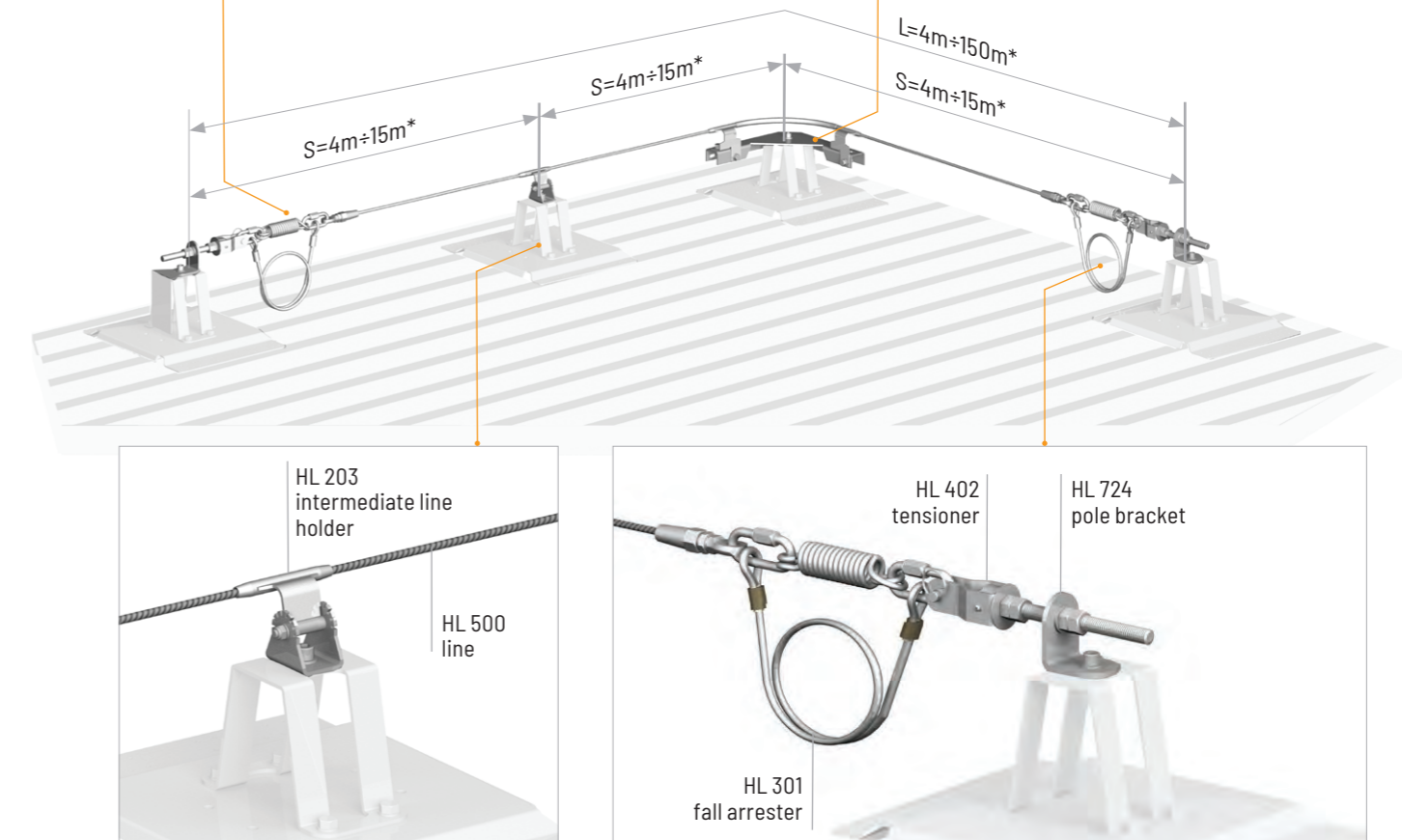
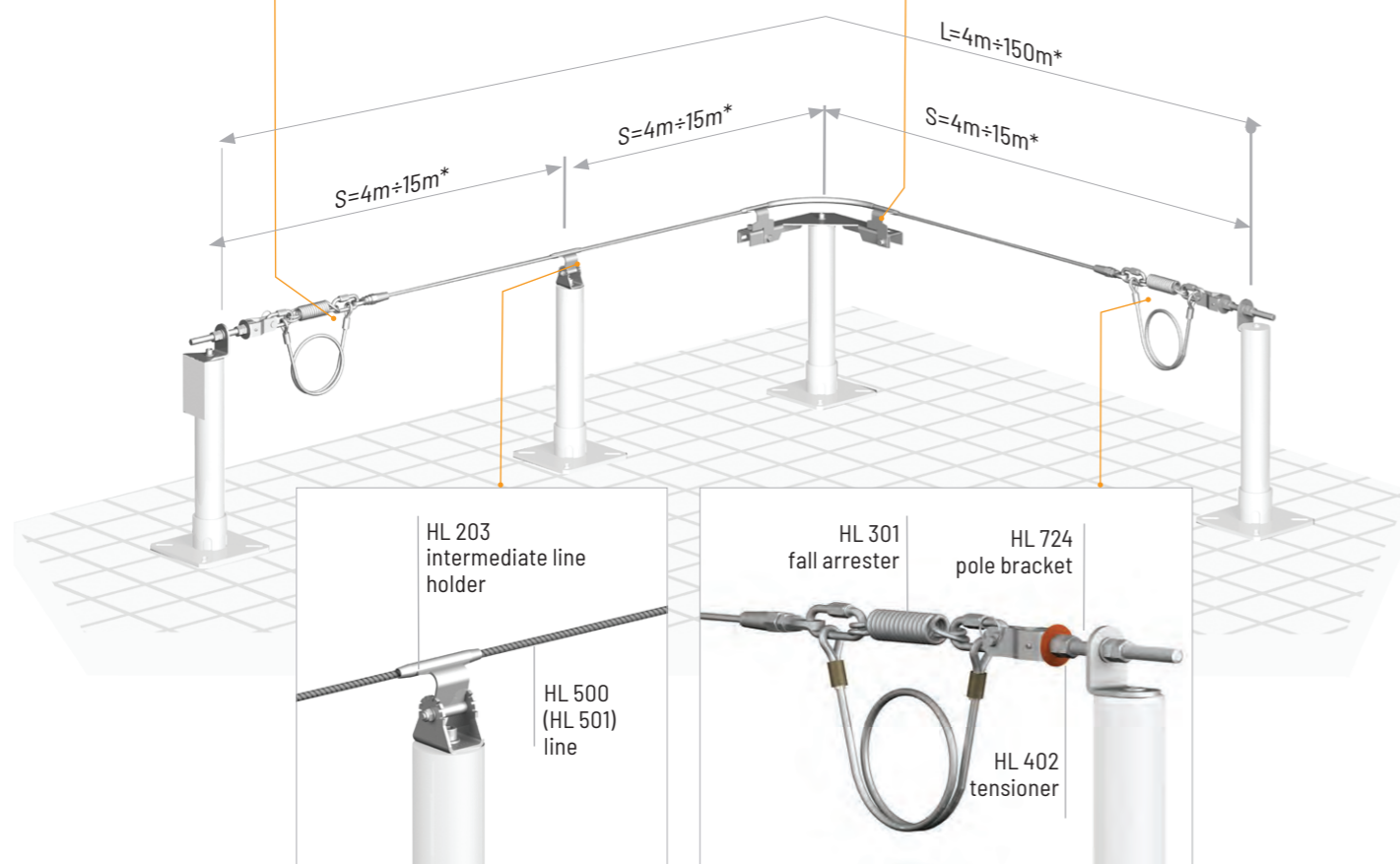
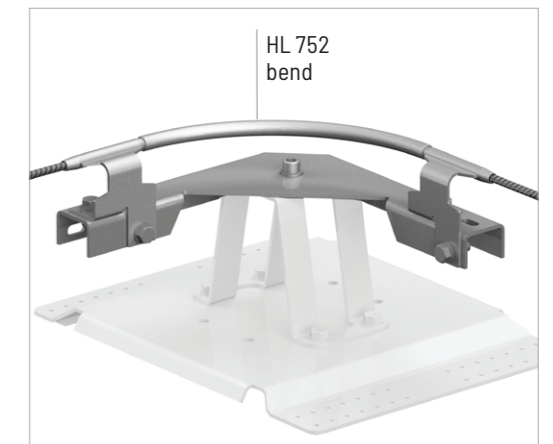
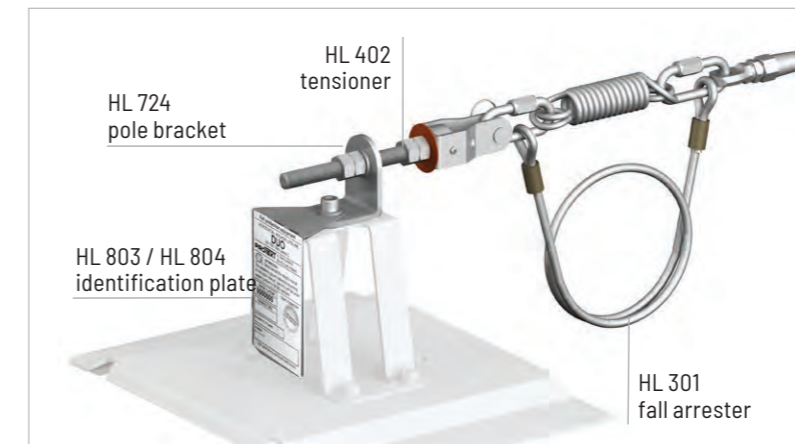
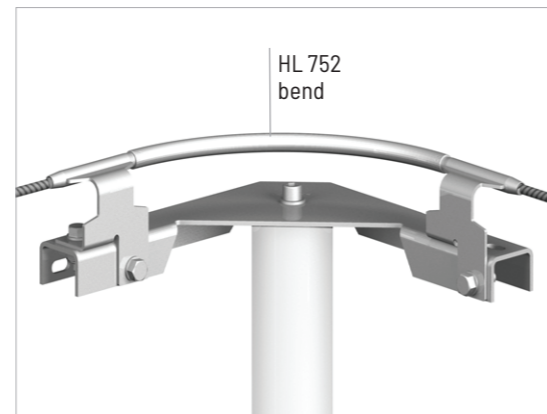
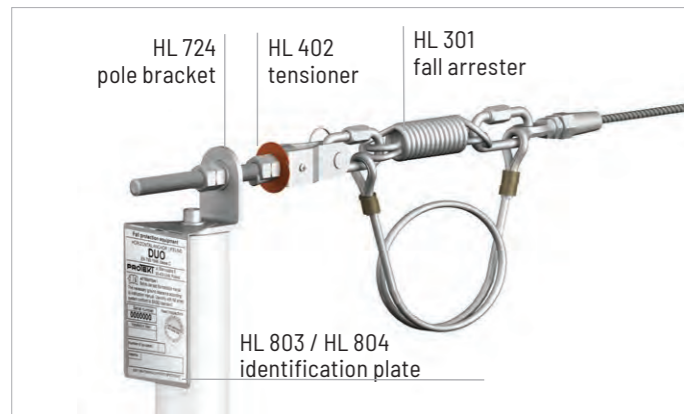

Values of force F transferred on lifeline [kN]\*

Total length of system [m]	15	50	100
Span length [m] 5	8,3	8,2	7,2
Span length [m] 15	7,8	8,5	8,3

Values of deflection D of lifeline [m]\*

Total length of system [m]	15	50	100
Span length [m] 5	0,6	0,7	0,8
Span length [m] 15	1,4	1,5	1,5

\*special solutions may include other length (for more information please contact our representatives). \*\* given indicative values and cannot be used for system design

Values of force F transferred on lifeline [kN]\*

Total length of system [m]	15	50	100
Span length [m] 5	8,3	8,2	7,2
Span length [m] 15	7,8	8,5	8,3

Values of deflection D of lifeline [m]\*

Total length of system [m]	15	50	100
Span length [m] 5	0,7	0,7	0,8
Span length [m] 15	1,5	1,4	1,5

\*special solutions may include other length (for more information please contact our representatives). \*\* given indicative values and cannot be used for system design

# Mounting end and intermediate points

## Line systems



Post type HL 720 of 450mm in height, made of stainless steel. For trapezoidal-sheet roof with thermal insulation or temporarily covered with, e.g. snow. Mounted with screws or rivets.

Post type HL 720-C



Post type HL 720 of 450mm in height, made of stainless steel. For standing seam type roofing, temporarily covered with, e.g. snow.

Post type HL 720-S5Z-400

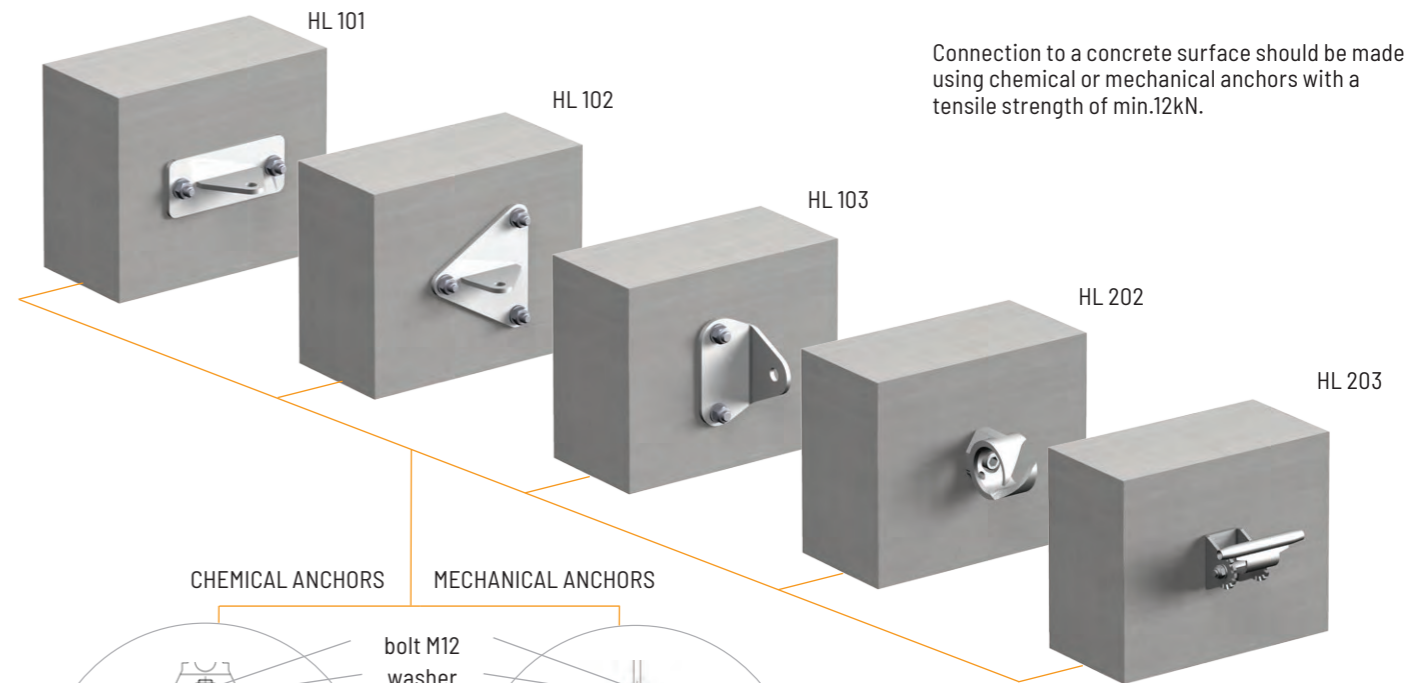

Connection to a concrete surface should be made using chemical or mechanical anchors with a tensile strength of min.12kN.

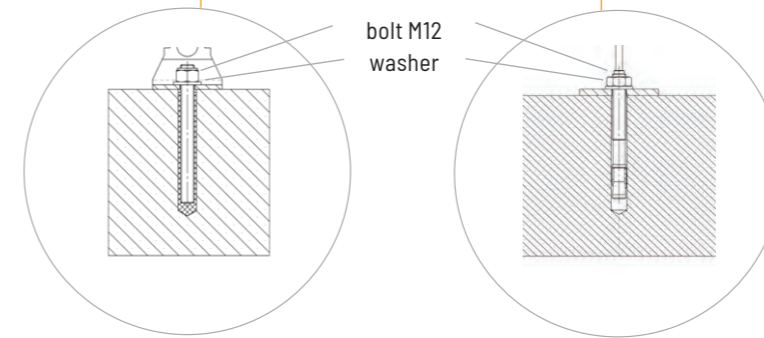

Compressive strength of the surface should be min. 25MPa. Strictly follow recommendations for installation given by manufacturers of respective anchors.

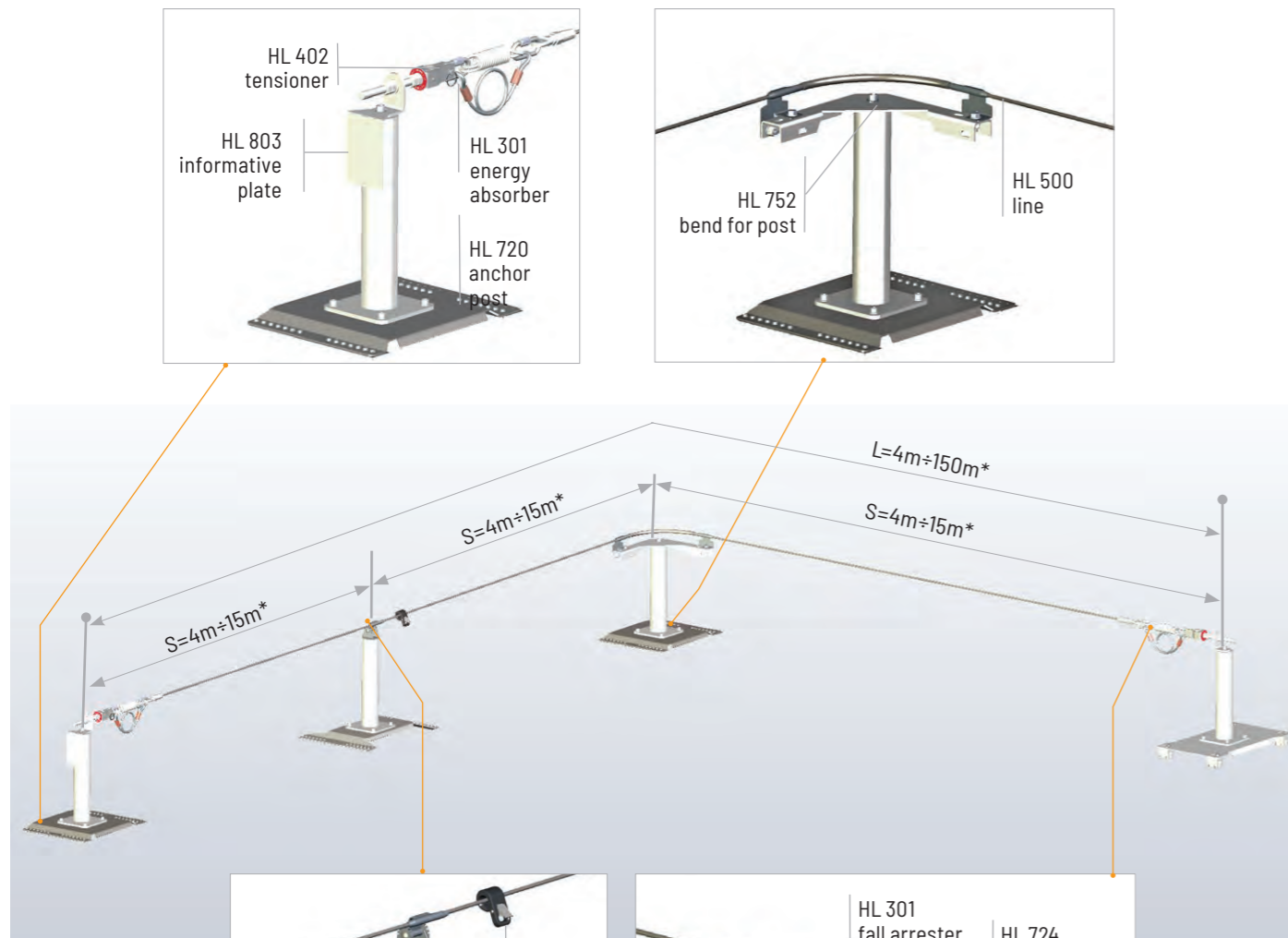

## Mounting end and intermediate points to steel profiles

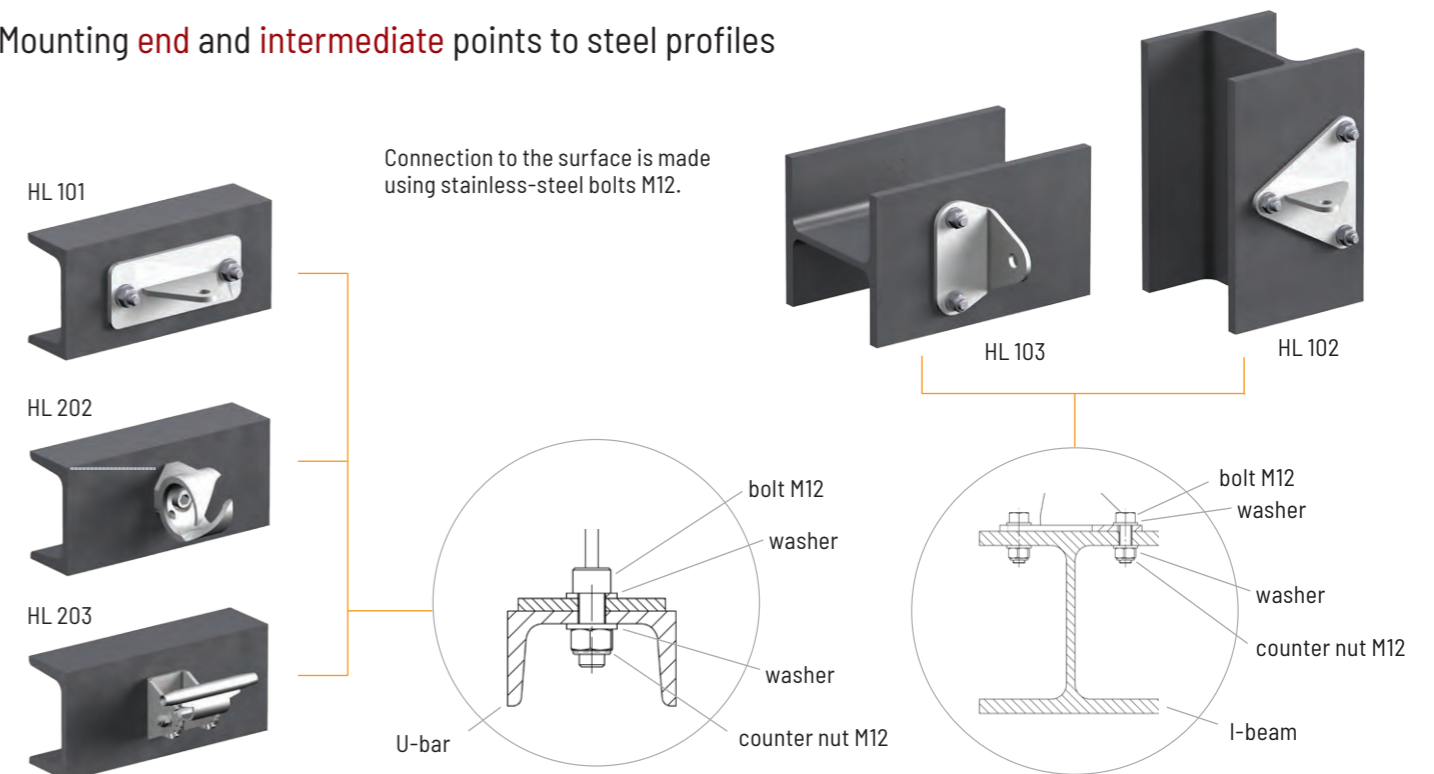

Values of force F transferred on lifeline [kN]\*

Total length of system [m]	15	50	100
Span length [m]	5	5,9	5,7
	15	7,6	7,6

Values of deflection D of lifeline [m]\*

Total length of system [m]	15	50	100
Span length [m]	5	0,9	0,95
	15	1,8	1,8

\*special solutions may include other length (for more information please contact our representatives). \*\* given indicative values and cannot be used for system design

# Mounting post HL 704

Line systems

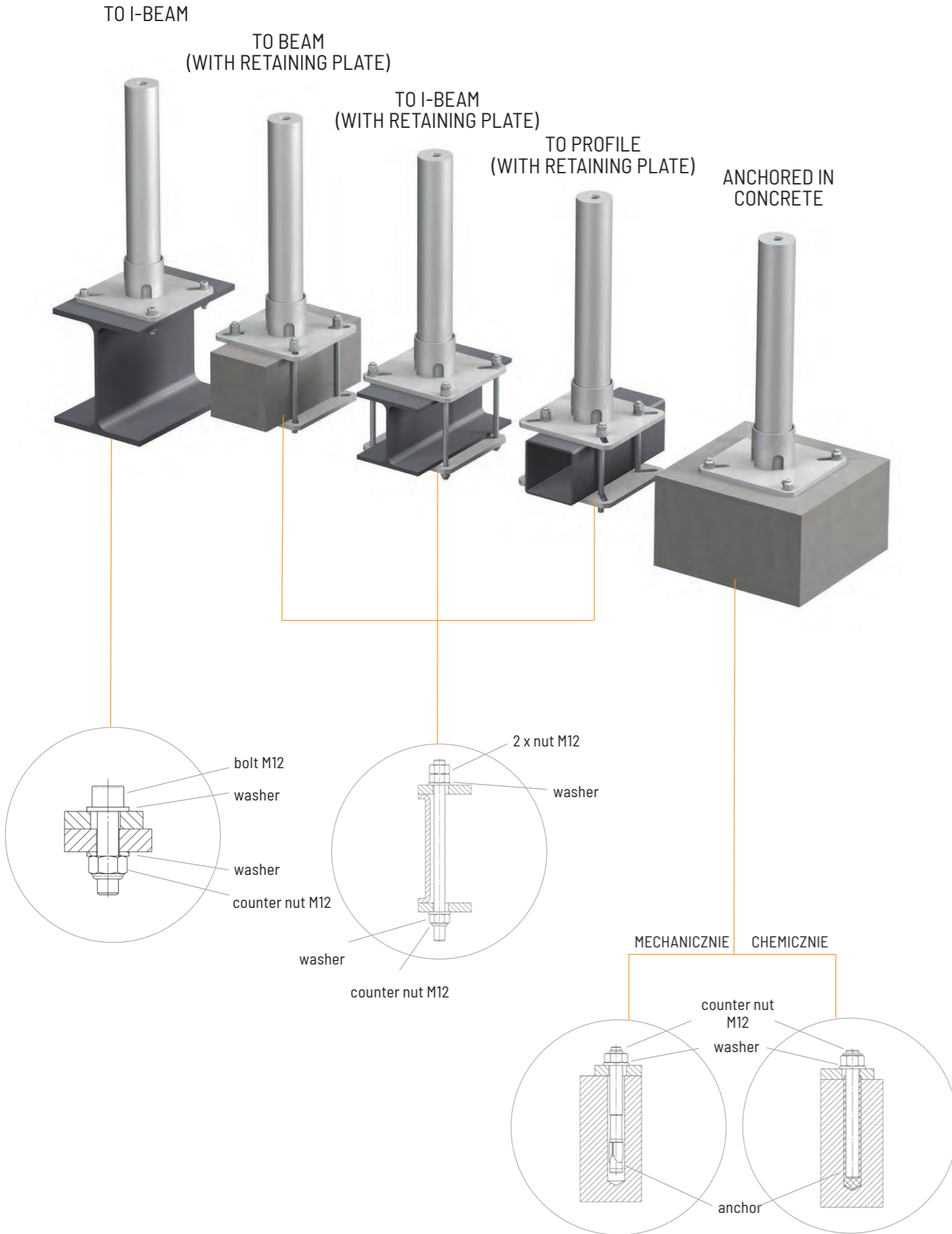

# Mounting posts HL 720, HL 760 to standing seam and trapezoidal sheets

Line systems

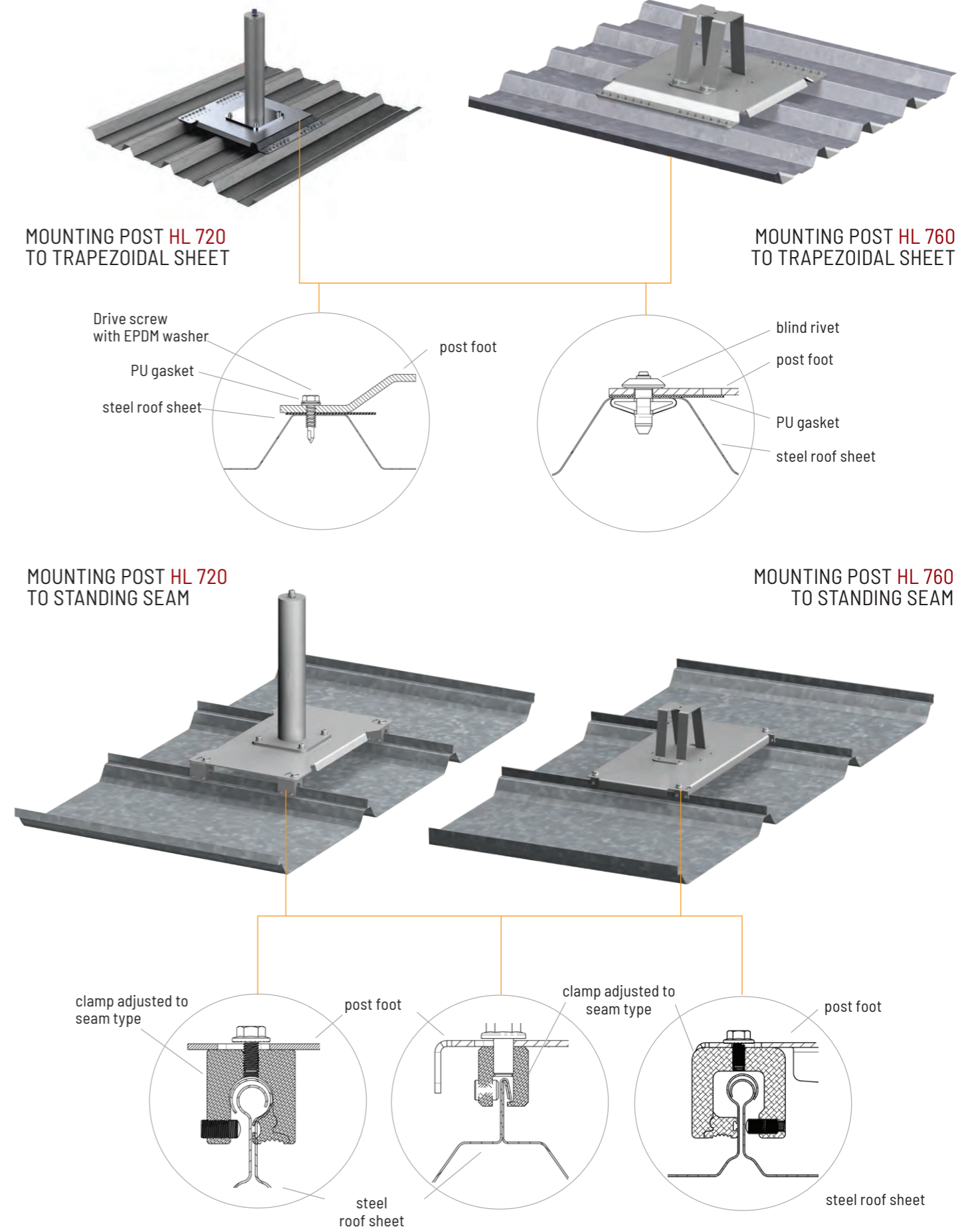

# DUO system components

## Line systems

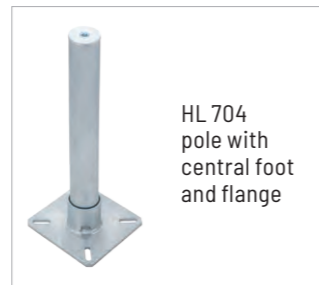
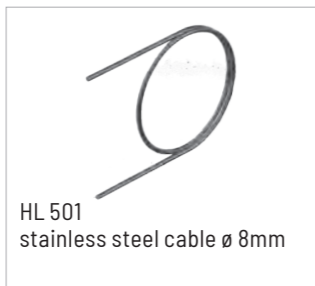
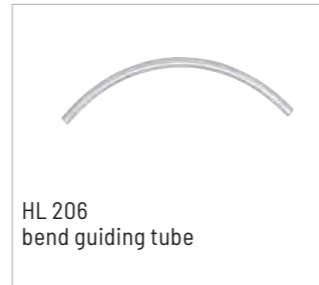



® Example configuration of DUO system.

# PROLINER

Horizontal anchorage system with double anchor line.

3 MAXIMUM USERS

Horizontal line anchor system PROLINER is a C class anchor device conforming to EN 795 and CEN /TS 16415. The system is intended for use by maximum 3 users at the same time. All the PROLINER system components are made of stainless steel. The trolley is the system's mobile anchor point for personal fall protection equipment. It enables mobility along the system while providing fall protection in the vertical. The anchor line being trolley's runway is made of double stainless steel cable of 8mm in diameter. Fall arrester is used to reduce forces affecting support structures, and return roll to properly tension the cable used within the system. Systems with lengths greater than 12m are equipped with intermediate supports enabling the trolley's run. The data plate includes basic information on use of the system and individual serial number, date of installation (month and year) and date of next inspection. The system is suitable for works in explosion-hazard zones.

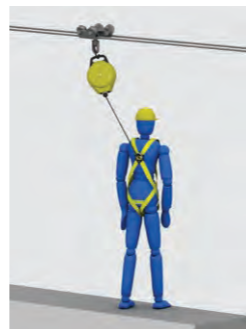

## Installation to ceiling / structure

Line systems

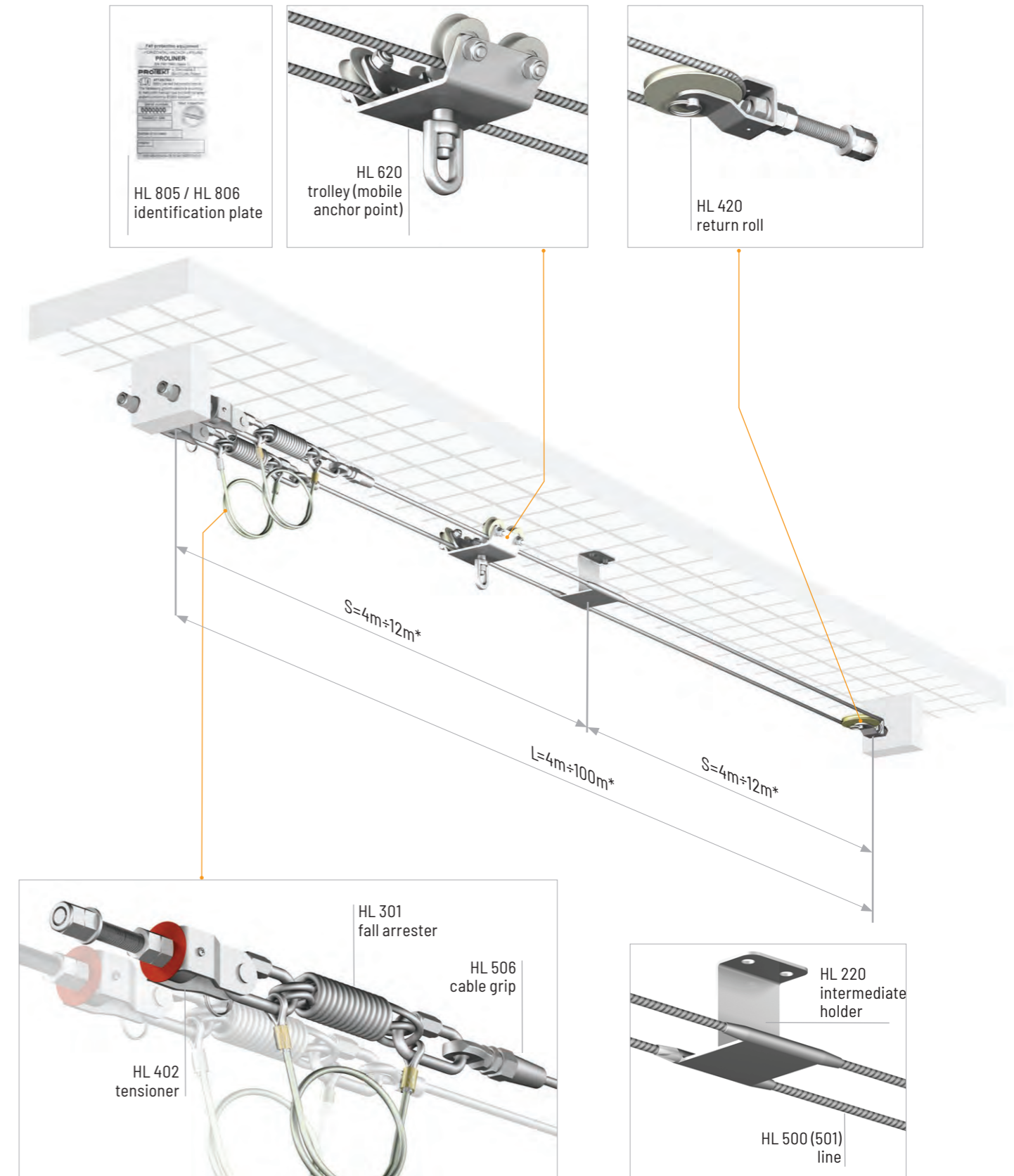

\* special solutions may include other length (for more information please contact PROTEKT representatives)

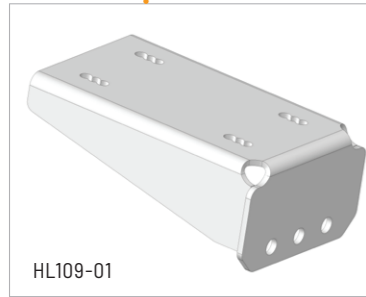
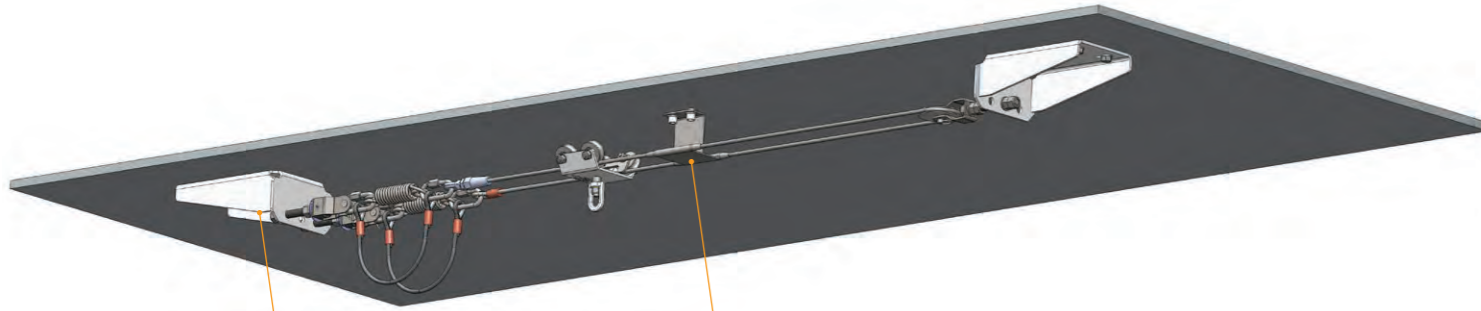

HL109-01

Stainless-steel mounting plate. Mounted with bolts or anchors on a horizontal surface.



HL221

Intermediate line holder, made of stainless steel. Mounted with bolts or anchors on a horizontal surface.

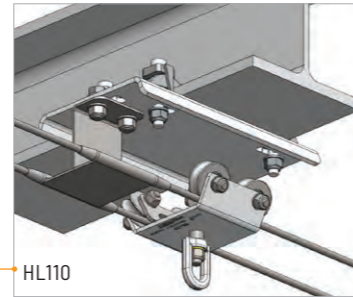

HL110

Set for installation of the system guided transversally to the beam. Mounting with lugs to I-beams. Materials: stainless steel and galvanized steel

HL 110- yy (where yy = S, M, L, 1VL, 2VL ...)

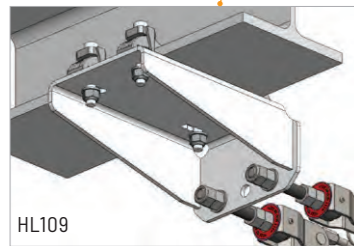
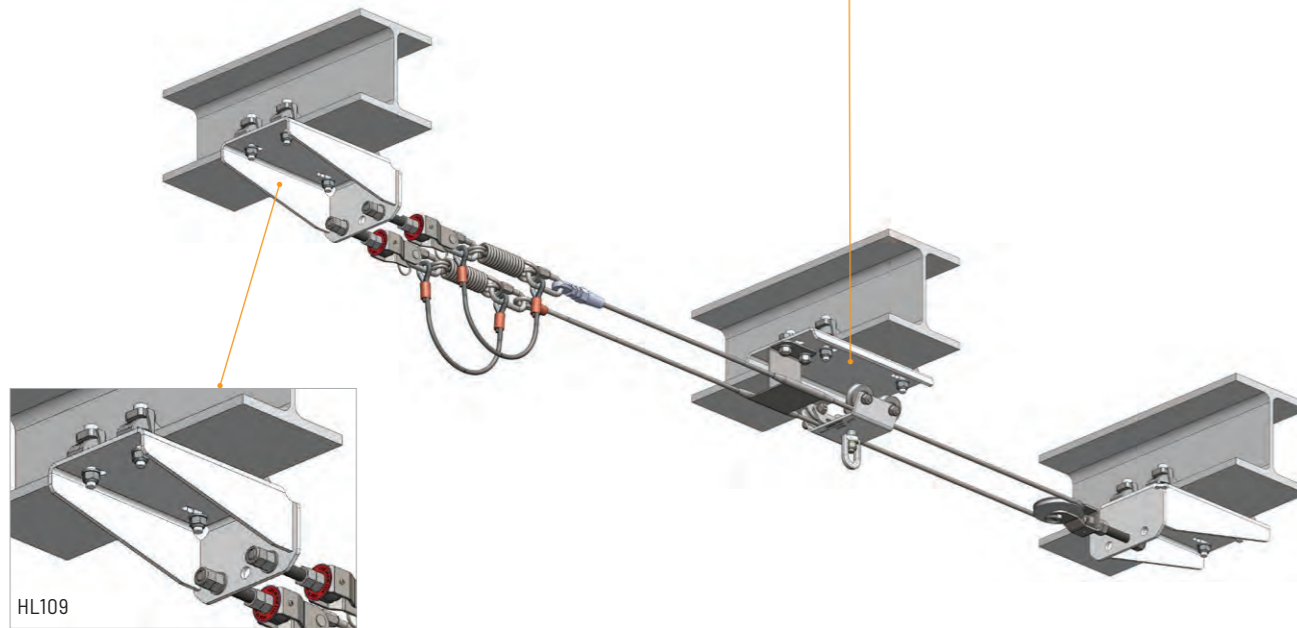

HL109

Set for installation of end points of the system guided transversally to the beam. Mounting with lugs to I-beams. Materials: stainless steel and galvanized steel

HL 109 - yy (where yy = S, M, L, 1VL, 2VL ...)

HL 110-xx + HL 111-xx + 4xHL 910 (where xx = 01, 02, 03, 04, 05)

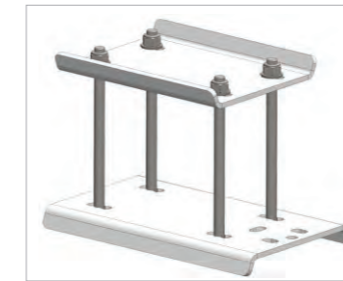

Set for installation of intermediate points of the system guided transversally to the beam. Mounting to closed sections, I-beams or U-bars. Material: stainless steel.

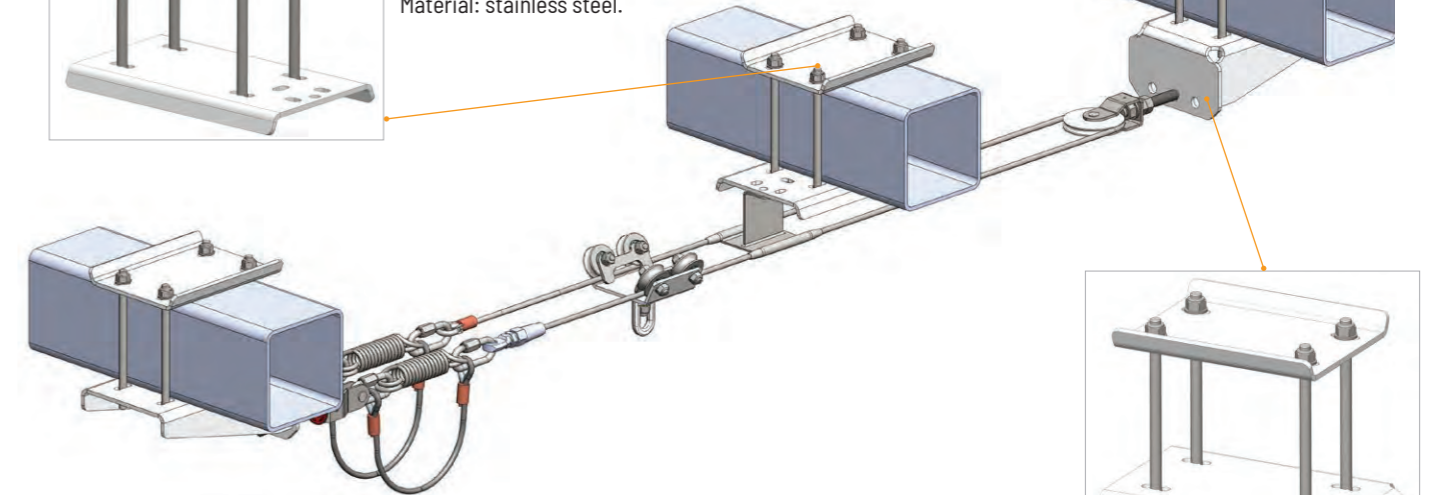

Set for installation of end points of the system guided transversally to the beam. Mounting to closed sections, I-beams, U-bars, etc. Material: stainless steel.

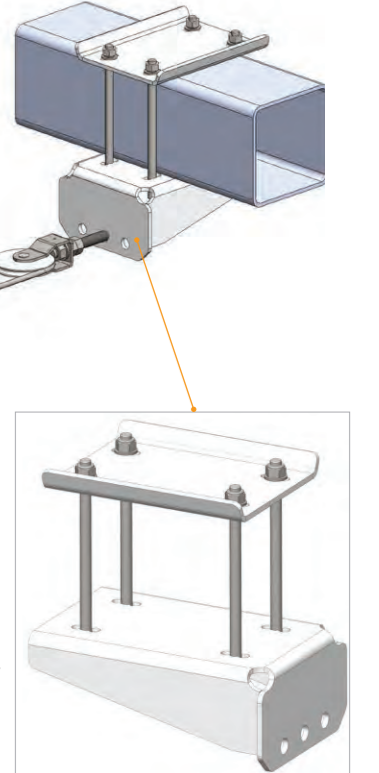

HL109-xx + HL111-xx + 4xHL910 (where xx = 01, 02, 03, 04, 05)



HL 115-xx + HL 111-xx + 4xHL 910 (where xx = 01, 02, 03, 04, 05)

Set for installation of end points of the system guided along the beam. Mounting to closed or open sections with various cross section shapes. Materials: stainless steel.

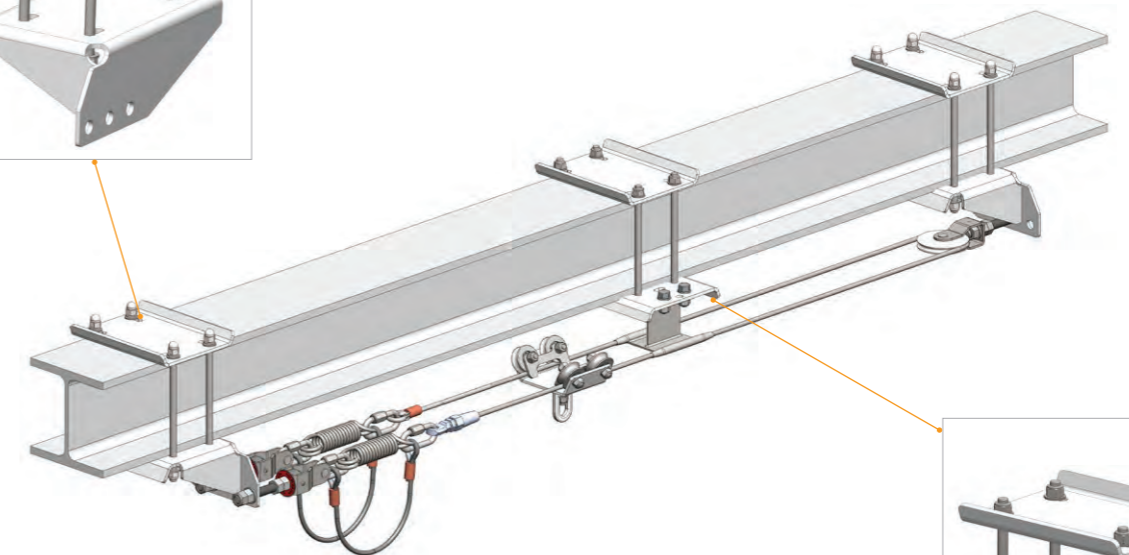

HL 110-xx + HL 111-xx + 4xHL 910 (where xx = 01, 02, 03, 04, 05)

Set for installation of intermediate points of the system guided along the beam. Mounting to closed or open sections with various cross section shapes. Materials: stainless steel.



# MONOLINE

Horizontal anchorage system with trolley and single anchor line.

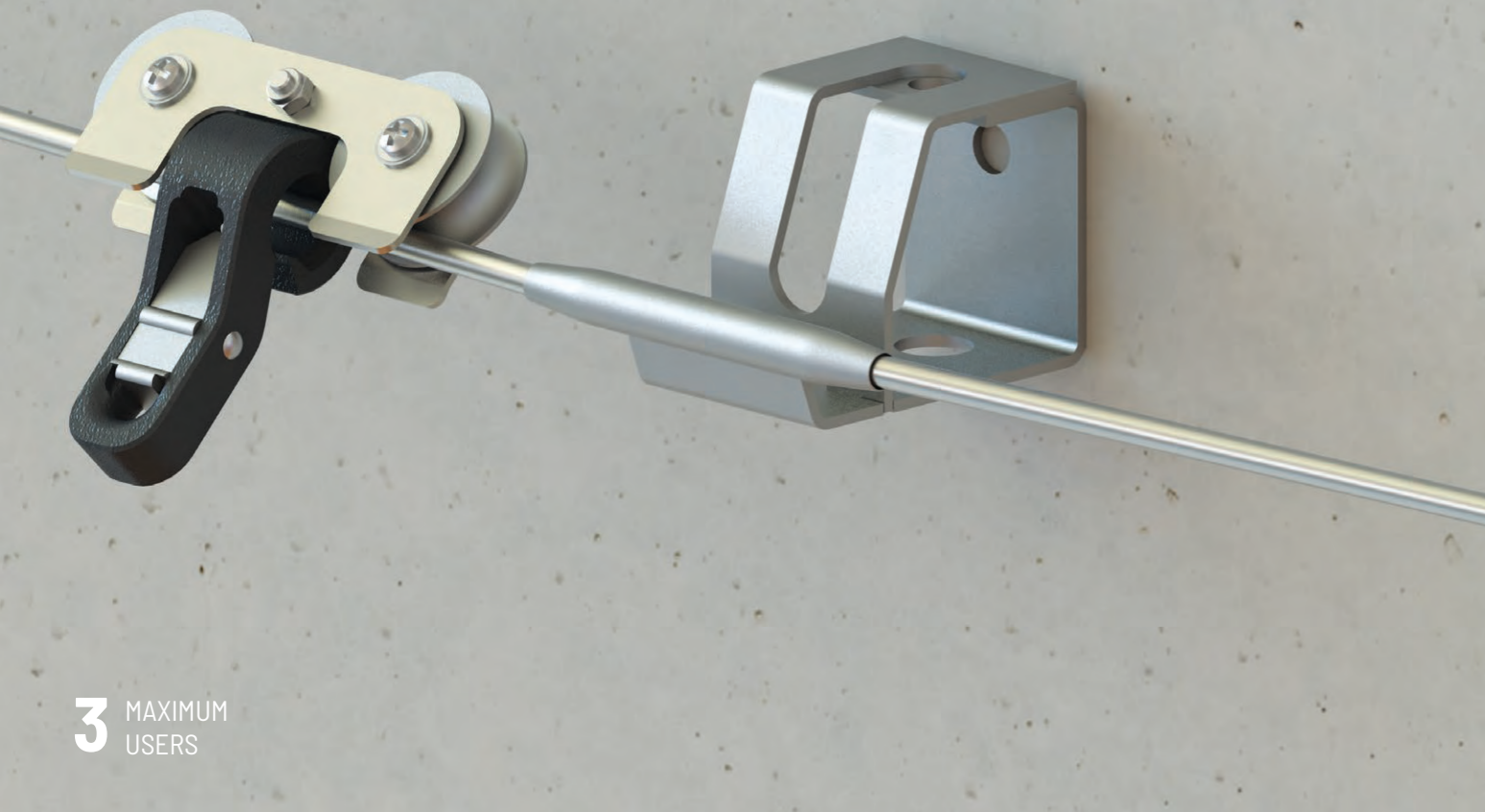

3 MAXIMUM USERS

The MONOLINE system concept is based on a use of a trolley being a mobile anchor point for personal fall arrest system which cooperates with a single steel anchor line. Such solution provides user with a high comfort of horizontal mobility because the trolley travels easily along the anchor line, which is comparable to rail systems. While it is possible to keep low investment costs, characteristic for line systems.

General features of system MONOLINE:

- Modular design and small number of components
- Quick installation in various configurations
- Can be used by 3 users at the same time

The system MONOLINE conforms to EN 795:2012 and CEN/TS 16415:2013. It is a C class anchor device intended for use with personal fall protection equipment.



## Installation to ceiling / floor / wall / structure

Line systems

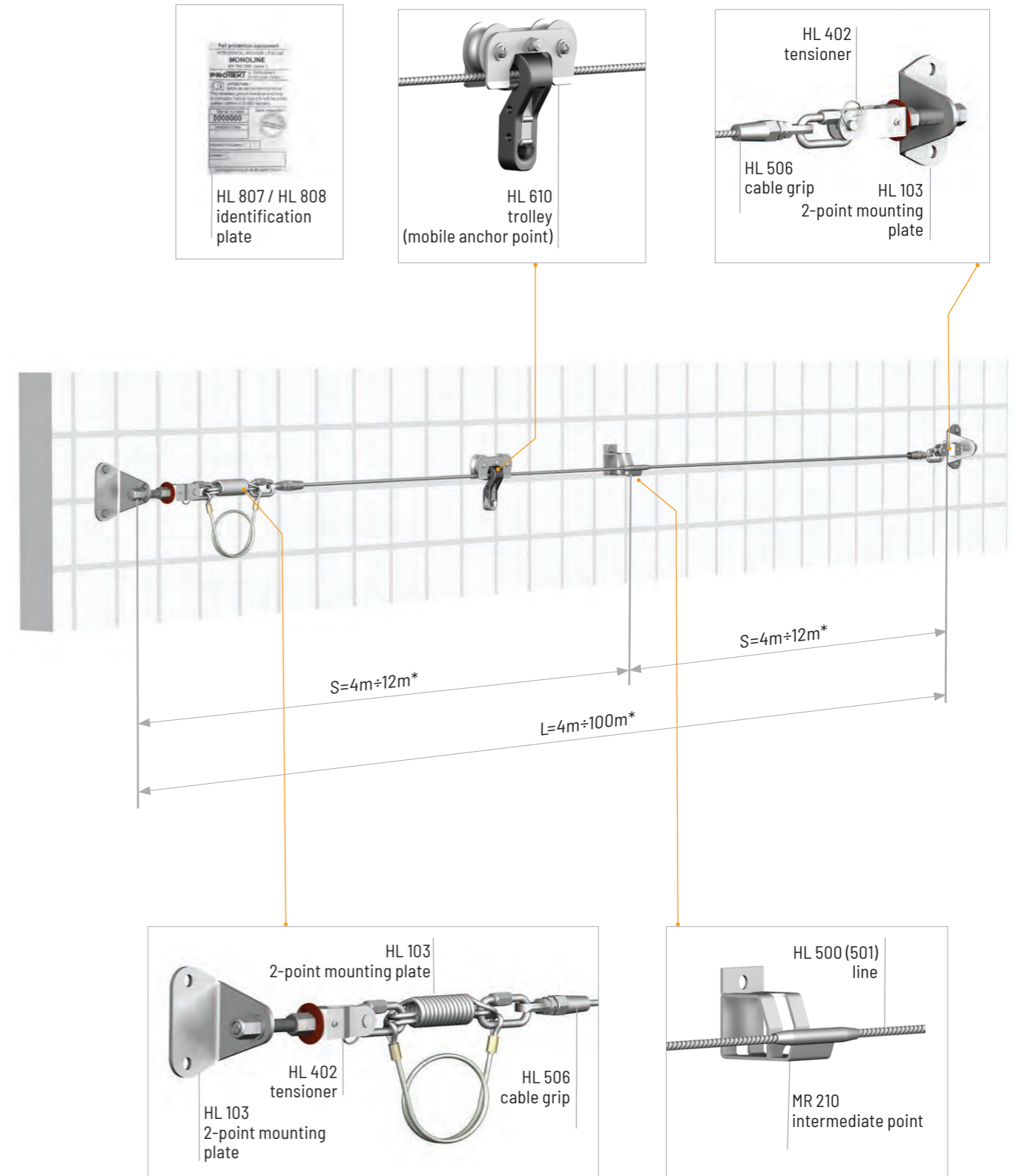

\* special solutions may include other length (for more information please contact our representatives)

# Mounting MONOLINE system

Line systems



Stainless-steel mounting plate. Can be used on various surface types.

HL103



Stainless-steel mounting plate. Designed for mounting on steel or high-strength concrete elements.

HL724

Set for installation of end of the system guided transversally to the beam. Mounting with lugs to I-beams.

Materials: stainless steel and galvanized steel



HL107

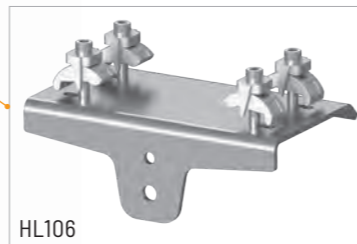

HL106

Set for intermediate points of the system guided transversally to the beam. Mounting with lugs to I-beams.

Materials: stainless steel and galvanized steel  
HL 106 - yy (where yy = S, M, L, 1VL, 2VL ...)

# Mounting MONOLINE system

Line systems



Set for end points of the system guided transversally to the beam. Mounting to closed or open sections.

Materials: stainless steel and galvanized steel

HL 107 - xx + HL 111 - xx + 4 x HL 910  
(where xx = 01, 02, 03, 04, 05)

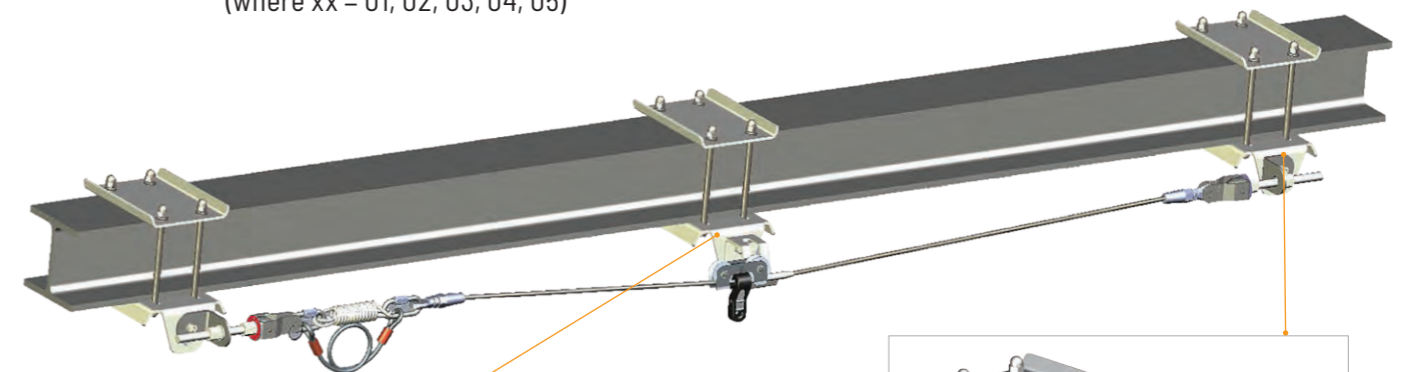

Set for intermediate points of the system guided along the beam. Mounting to closed or open sections with various cross section shapes.

Materials: stainless steel and galvanized steel

HL107 - xx + HL111 - xx + 4 x HL910  
(where xx = 01, 02, 03, 04, 05)

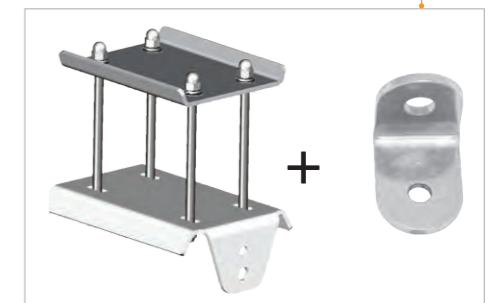

HL 107 - xx + HL 111 - xx + 4 x HL 910 + HL 724  
(where xx = 01, 02, 03, 04, 05)

Set for end points of the system guided along the beam. Mounting to closed or open sections with various cross section shapes.

Materials: stainless steel.

MONOLINE system components on page 67

# PROLINER system components

## Line systems



# MONOLINE system components

## Line systems

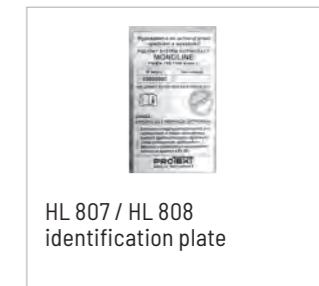
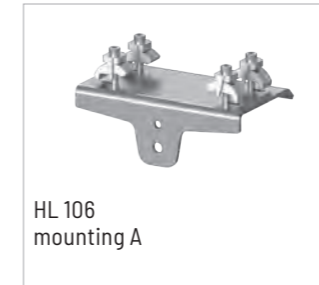

# TRASER

Horizontal anchorage system with rail guide.

**3** MAXIMUM USERS

Rail anchorage system TRASER is a D class anchor device conforming to EN 795:2012 and CEN /TS 16415. Designed for connection of personal fall protection equipment. The system enables horizontal mobility and provides protection for up to 3 users at the same time. The system comprises a horizontal rail as a truss, trolley being a mobile anchor point for personal fall protection equipment, runway end locks, rail guide connectors and elements for mounting the guides on a fixed structure. The rail guide is made of hot-dip galvanized steel. Trolley, connectors, runway locks and elements for mounting the guides on a fixed structure are made of hot-dip galvanized, galvanized and stainless steel or plastic. The system is suitable for works in explosion-hazard zones.



## Installation to ceiling / structure

Rail systems

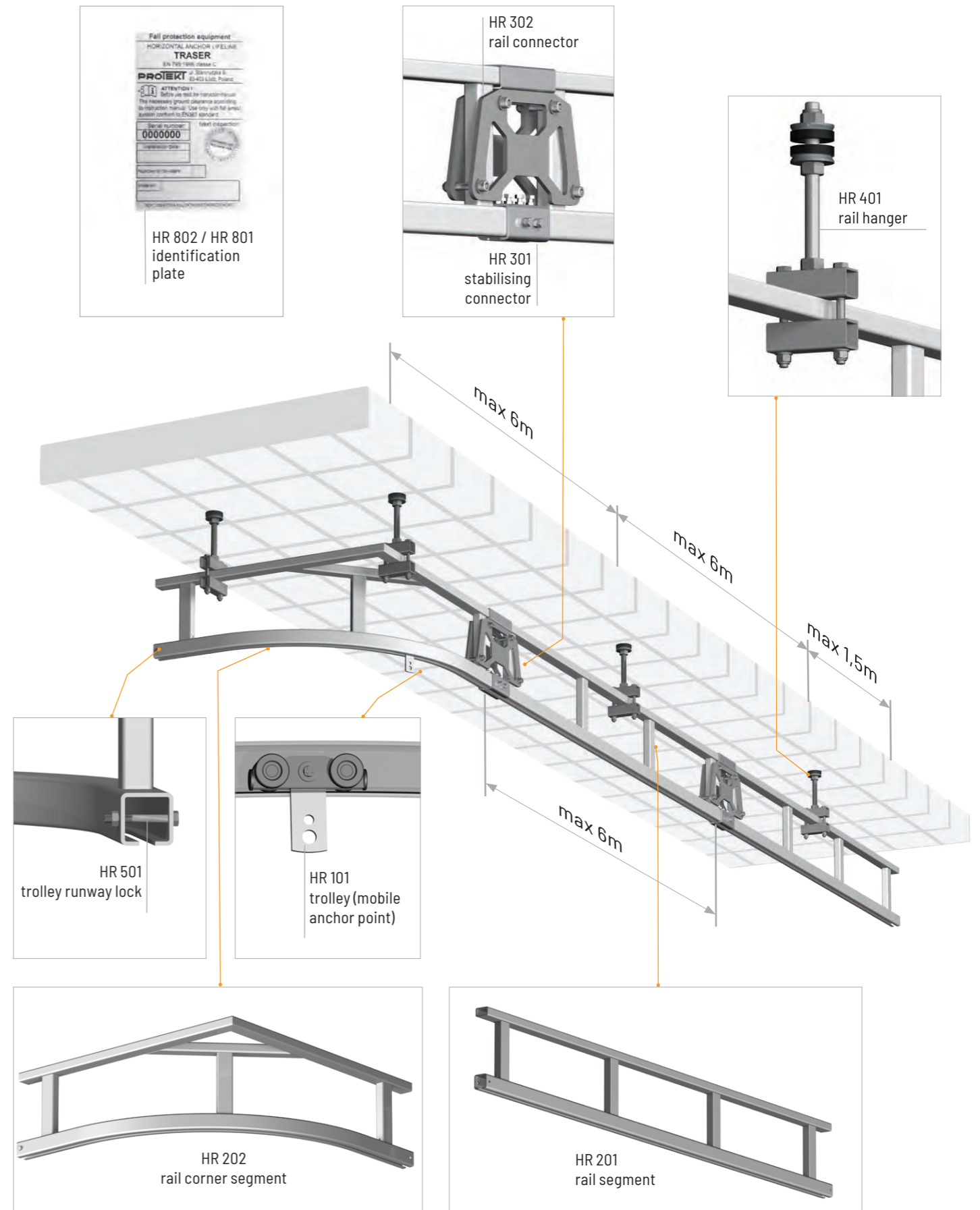

# TRASER system components

## Rail systems

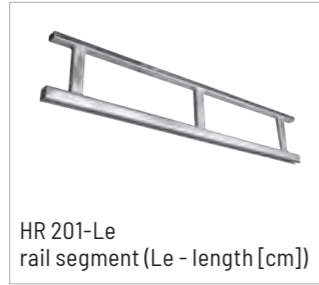

® Example configuration of TRASER system on a ramp.

# MARAN

Horizontal anchorage system with rail guide.



2 MAXIMUM USERS

The system is used for attaching personal fall protection system on a fixed structure and at the same time enables mobility while keeping full protection. The system can be used by 2 users at the same time, each of whom should be attached to a separate trolley. The rail anchorage system comprises a rail being the trolley runway (mobile anchor point for personal fall protection equipment), runway end locks, rail guide connectors, bends and elements for mounting the guide on a fixed structure. The rail guide is made of aluminium alloy. Trolley, rail connectors, runway locks, elements for mounting the guide on a fixed structure are made of aluminium alloy, and connecting elements (bolts) are made of stainless steel. The system MARAN is a D class anchor device conforming to EN 795:2012 and CEN /TS 16415. The system is suitable for works in explosion-hazard zones.

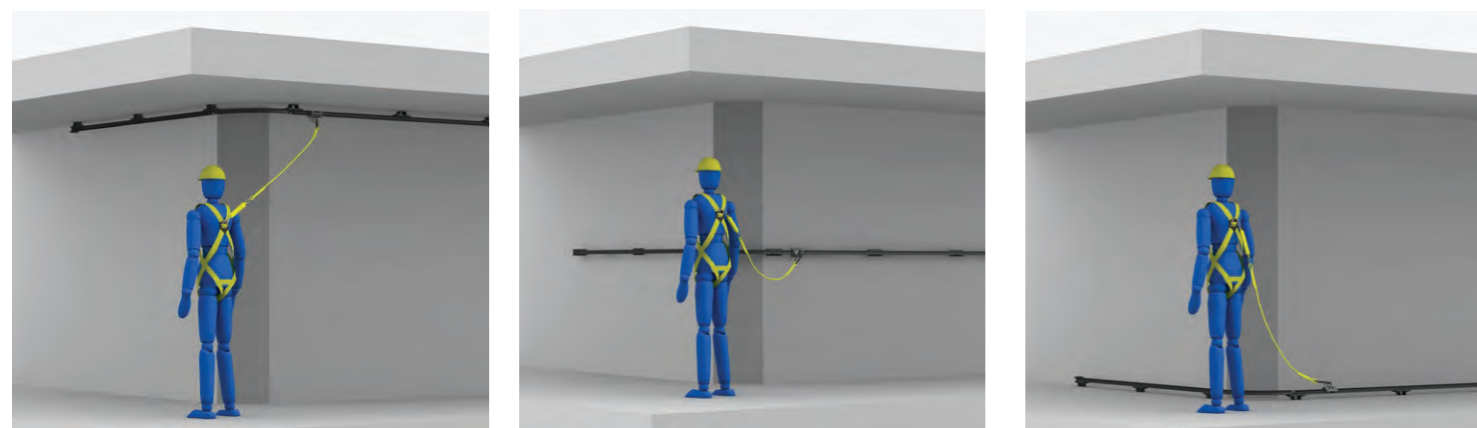

## Installation to ceiling / floor / wall / structure

Rail systems

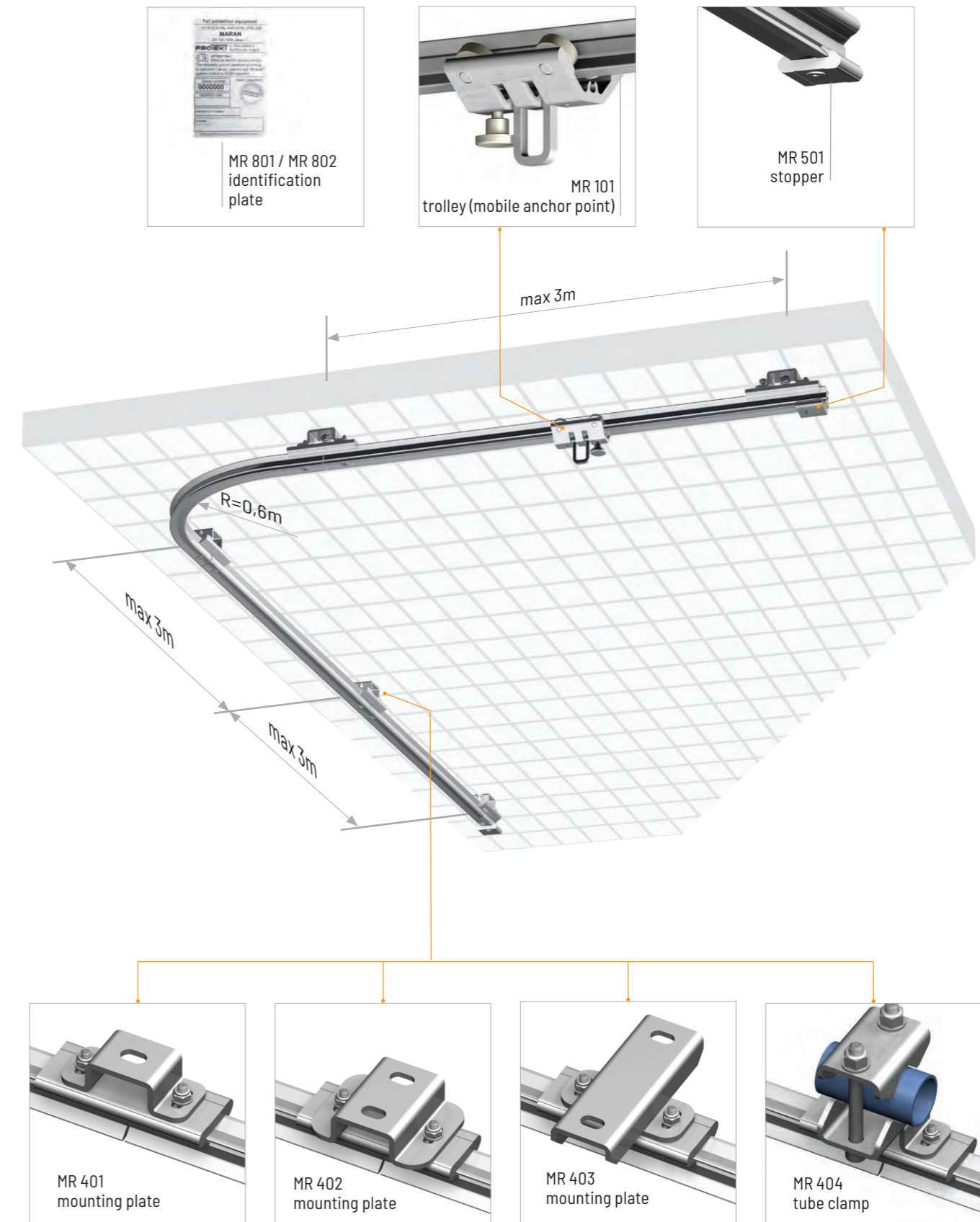

# MARAN system components

## Rail systems

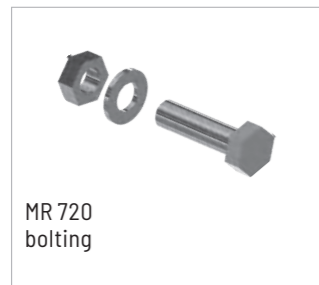



® Example configuration of MARAN system on a wall.



**SKC  
BLOCK**

Vertical anchor  
system for ladders

2 MAXIMUM  
USER

System SKC-Block is designed to protect one person ascending and descending vertical ladders against fall from a height. The system can be installed on any type of fixed ladders onto structures such as chimneys, towers, silos, masts or buildings. The essential element within the system is a line grab, installed on a steel cable of 8 mm in diameter, connected to a front attachment D-ring on full body harness. General elements within the system such as cable, guided type mechanism, cable connector, steel bolt clamps and tensioner are all made of stainless steel. Permanent vertical anchorage system SKC-BLOCK is a guided type fall arrester with a rigid anchor line and an energy absorbing and connecting component according to EN 363. System SKC -BLOCK meets requirements of Regulation of the European Parliament 2016/425. The system comprises vertical anchor line made of stainless steel cable of 8mm in diameter. Lower end of the anchor line is equipped with a tensioner made of stainless steel. Upper end of the anchor line is mounted on a fixed structure by means of stainless steel connector AZ 090. Vertical anchor line of up to 10m in length is equipped with line guide-wire (ref. AC 921) to protect anchor line against vibrations caused by e.g. wind. Slide is user's personal equipment installed on anchor line if a fall protection system is to be used. The slide travels along the line up and down as with user's normal mobility, and in the case of user's fall it is locked on the line to arrest the fall.

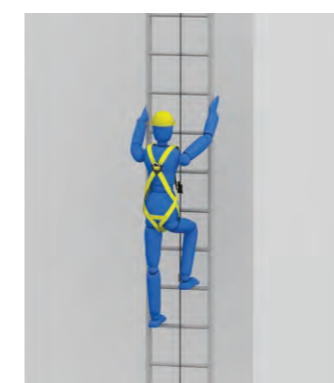
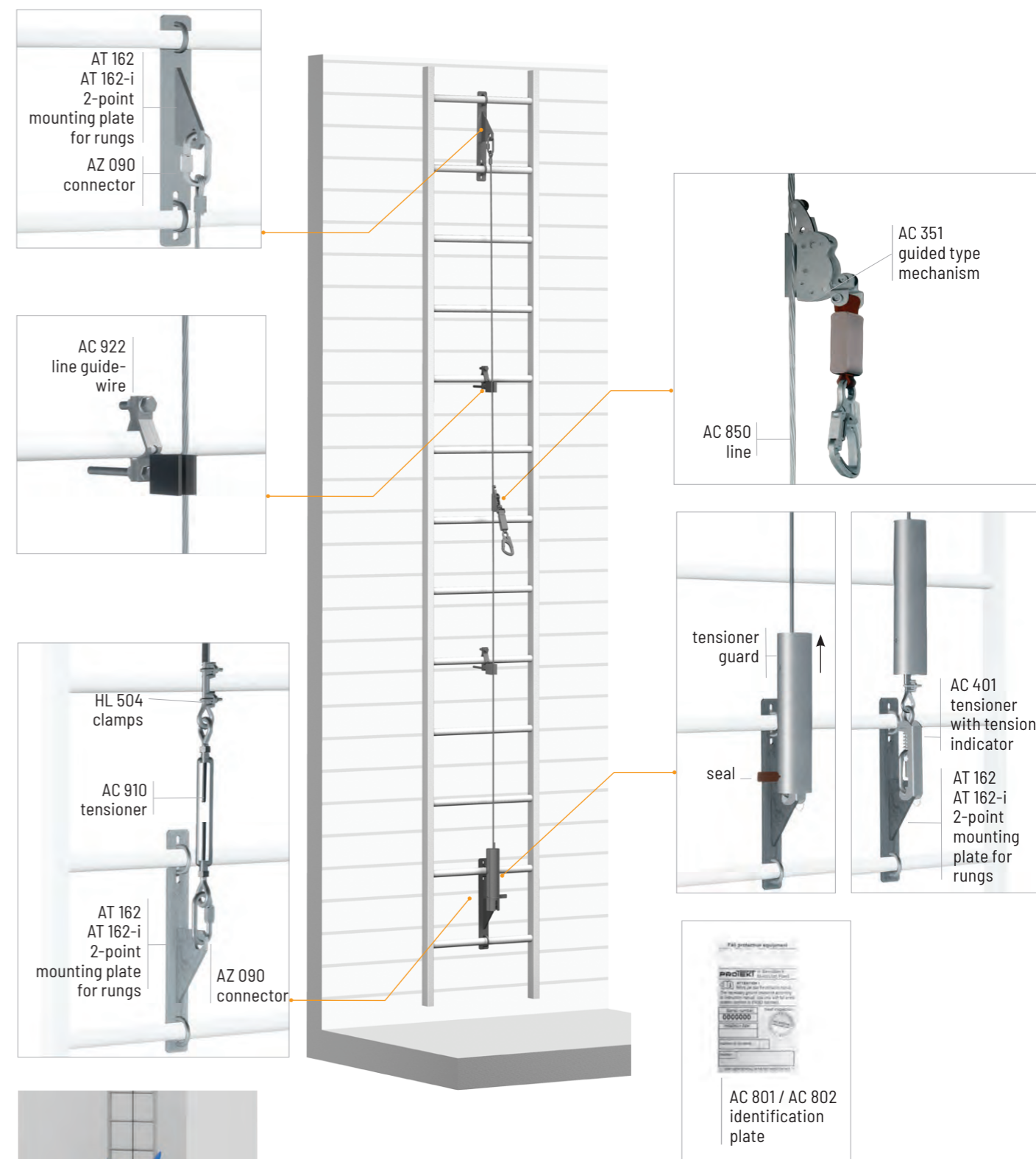

# AC 360

Vertical anchor system for ladders.



Fall arrester with rigid anchor line - System AS 360 is designed to provide protection for max. 2 users at the same time during their mobility in the vertical. The device complies with EN 353-1. The system can be installed on any type of fixed ladders onto structures such as chimneys, towers, masts or buildings. The essential element within the system is a guided type mechanism, installed on a steel cable of 8 mm in diameter, connected to a front attachment D-ring on full body harness. General elements within the system such as cable, guided type mechanism, cable connector, steel bolt clamps and tensioner are all made of stainless steel. System AC 360 meets requirements of Regulation of the European Parliament 2016/425. The system comprises vertical anchor line made of stainless steel cable of 8mm in diameter (ref. AC 850). Upper end of the anchor line is equipped with an energy absorber (ref. AC 361 / AC 362). Lower end of the anchor line is equipped with a tensioner (ref. AC 910). Upper and lower ends of the anchor line are mounted securely on a fixed structure by means of connector AZ 090. Vertical anchor line with length of up to 10m is equipped with line wire-guide (AC 922) to protect anchor line against vibrations caused by e.g. wind. Slide (AC 360) is user's personal equipment installed on the anchor line if a fall protection system is to be used. The slide travels along the line up and down as with user's normal mobility, and in the case of user's fall it is locked on the line to arrest the fall.

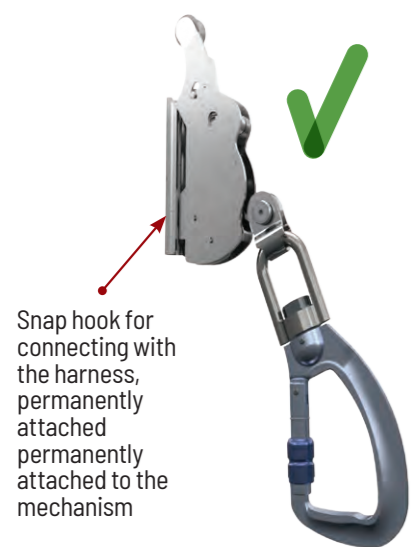

Snap hook for connecting with the harness, permanently attached permanently attached to the mechanism

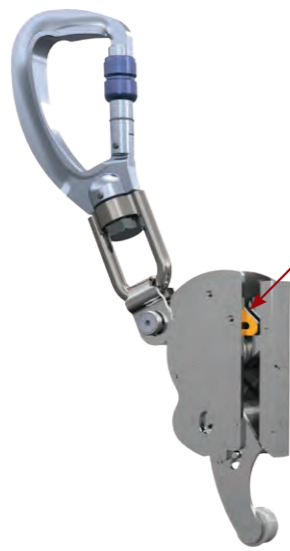

Protection against incorrect installation on the rope.

In case of an attempted incorrect installation, the locking device slides out.



## Installation to a ladder

Line systems

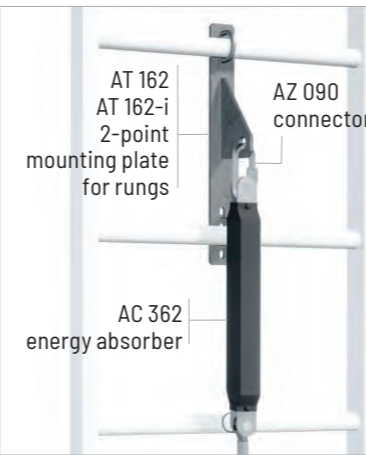
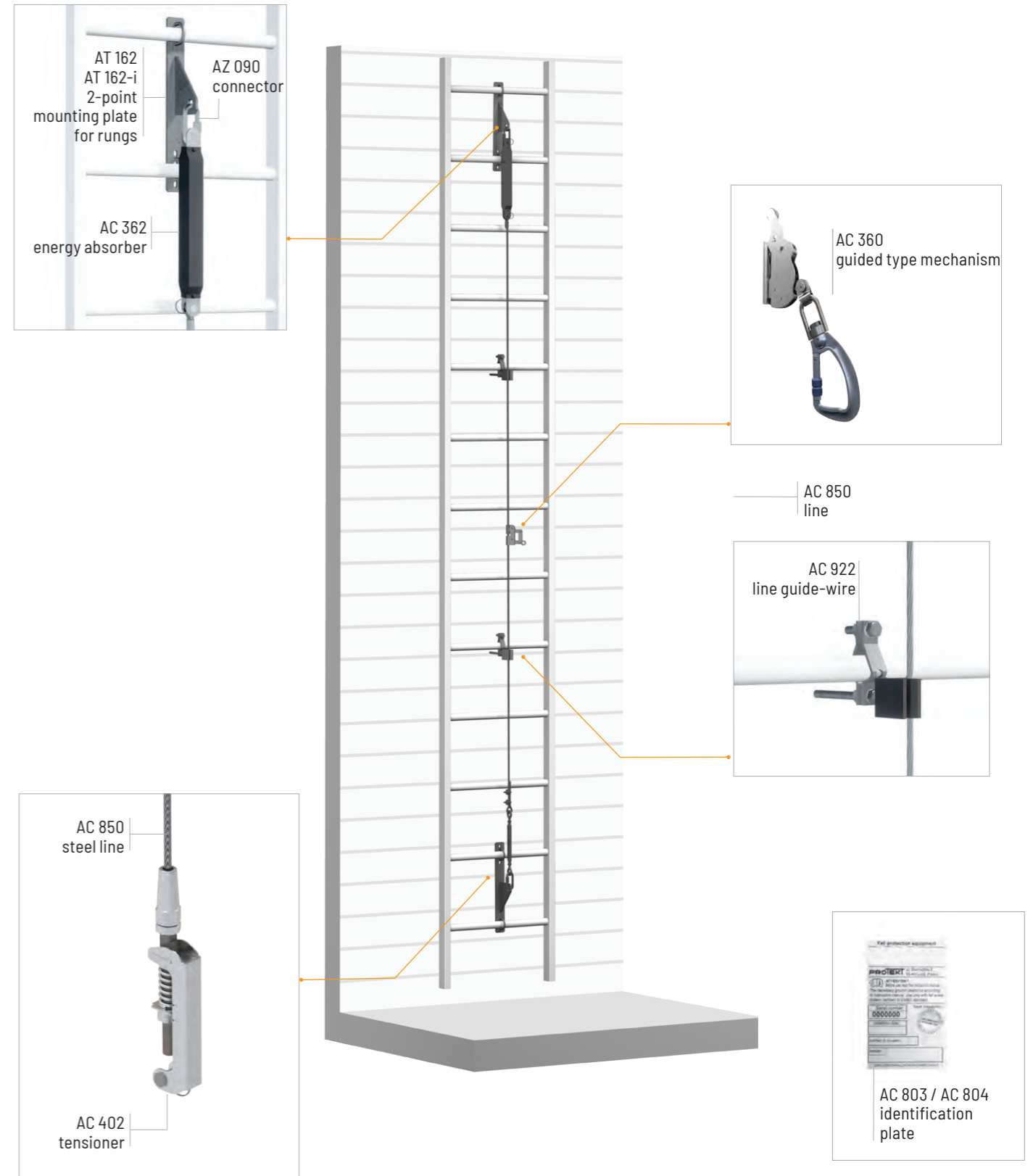

EXAMPLE CONFIGURATIONS OF SYSTEM ELEMENTS EXTENDED SYSTEM TO

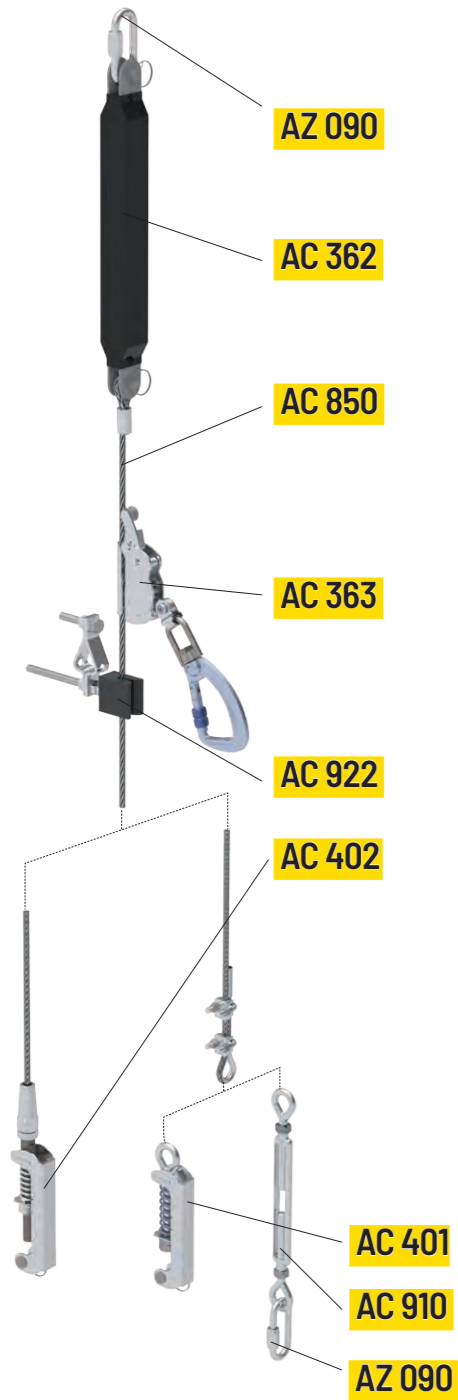

EXTENDED SYSTEM TO FOR EASY EXIT, E.G. TO THE ROOF

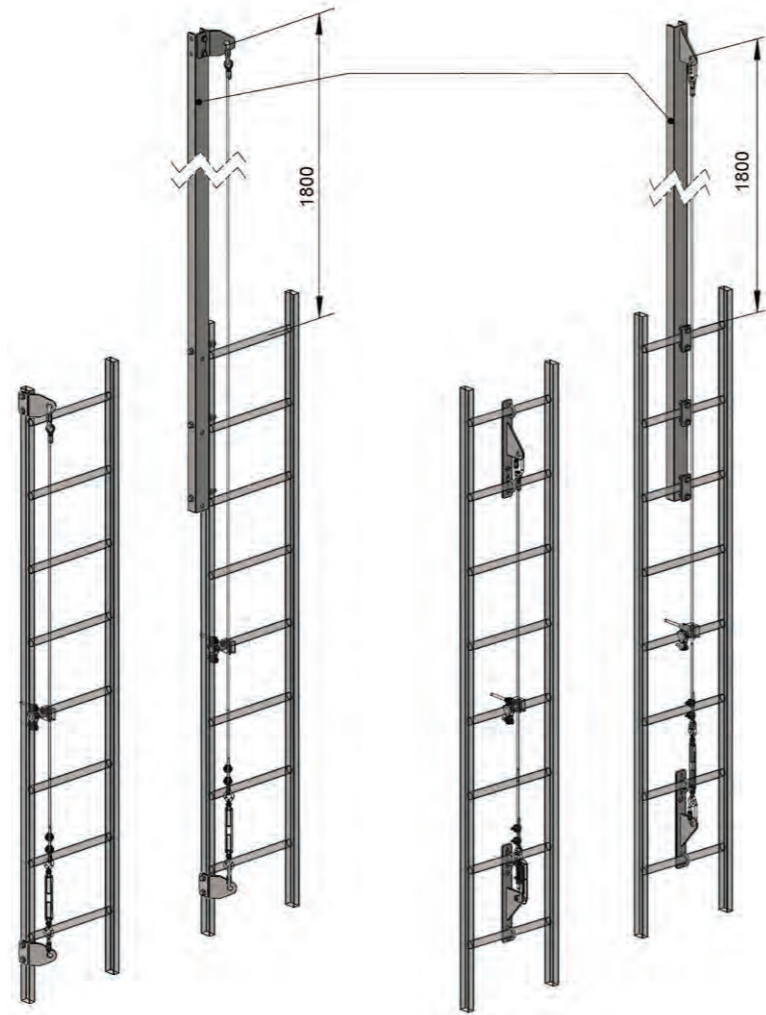

Side installation

Installation in ladder axis

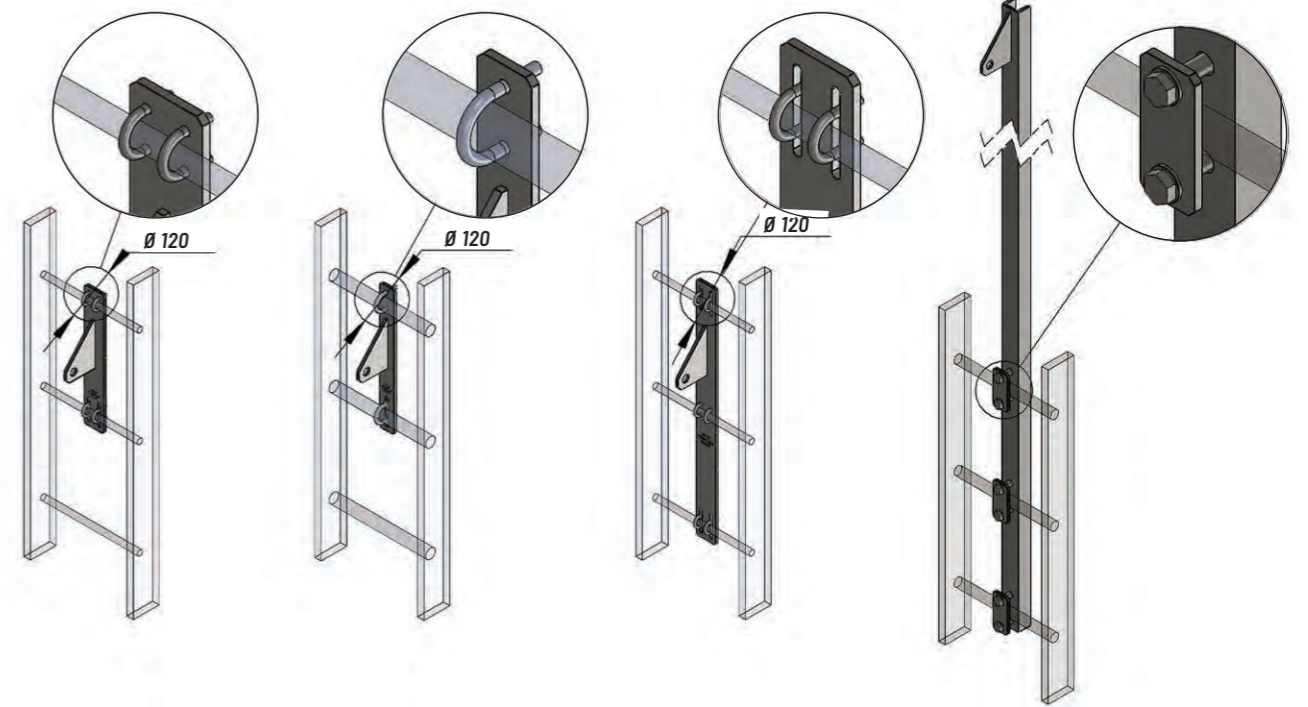

AT161 - Hot-dip galvanized steel

AT162 - Hot-dip galvanized steel

AT163 - Hot-dip galvanized steel

AT165 - Hot-dip galvanized steel

AT161i - Stainless steel

AT162i - Stainless steel

AT163i - Stainless steel

Rung dimensions: up to Ø55 mm

Rung dimensions:  
AT 161 (Ø12 - Ø22)  
(Ø12 - Ø18)  
AT 161i (Ø14 - Ø22)  
(Ø12 - Ø20)

Rung dimensions:  
AT 162 (Ø20 - Ø63)  
(Ø18 - Ø30)  
AT 162i (Ø20 - Ø36)  
(Ø20 - Ø32)

Rung dimensions:  
AT 163 (Ø12 - Ø22)  
(Ø12 - Ø18)  
AT 163i (Ø14 - Ø22)  
(Ø12 - Ø20)

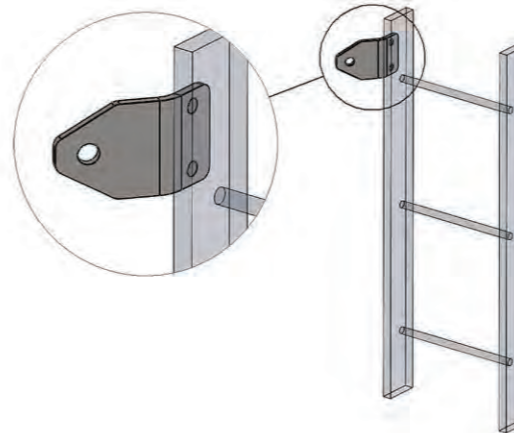



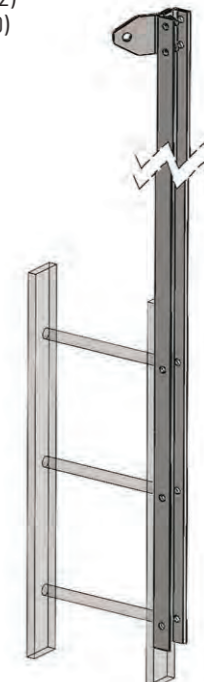









AT160 - Hot-dip galvanized steel  
AT160i - Stainless steel



AT166 - Hot-dip galvanized steel













## SKC - BLOCK system components

### Line systems

 AT 160 / AT 160-i side mounting plate (galvanized steel / stainless steel)	 AT 161 / AT 161 - i 4-point mounting plate for rungs (galvanized steel / stainless steel)	 AT 162 / AT 162 - i 2-point mounting plate for rungs (galvanized steel / stainless steel)	 AT 163 - i 6-point mounting beam for rungs (galvanized steel)
 AT 165 / AT 165 - i 3-point mounting plate for rungs (galvanized steel / stainless steel)	 AC 850 lanyard	 AC 401 tensioner for 2 persons	 AC 402 tensioner for 2 persons
 AZ 090 connector (stainless steel)	 AC 801 / AC 802 informative plates (stainless steel / PVC)	 AC 351 guided type mechanism	 AC 922 line guide-wire

## AC 360 system components

### Line systems

 AT 160 / AT 160-i side mounting plate (galvanized steel / stainless steel)	 AT 161 / AT 161 - i 4-point mounting plate for rungs (galvanized steel / stainless steel)	 AT 162 / AT 162 - i 2-point mounting plate for rungs (galvanized steel / stainless steel)	 AT 163 6-point mounting beam for rungs (galvanized steel)
 AT 165 / AT 165 - i 3-point mounting plate for rungs (galvanized steel / stainless steel)	 AC 850 lanyard	 AC 910 tensioner (stainless steel)	 AC 922 line guide-wire
 AZ 090 connector (stainless steel)	 AC 363 mechanism clamp-and-slide mechanism	 AC 362 energy absorber for 2 users	 AC 803 / AC 804 informative plates (stainless steel / PVC)
 AC 402 tensioner for 2 persons			



® Example configuration  
of system SKC - BLOCK in ladder axis.

# AC 520

Mast ladder with integrated vertical anchorage system.

**2** MAXIMUM USERS

System AC 520 is a guided type fall arrester with a rigid anchor line, being an energy absorbing and connecting component according to EN 353. System AC 520 meets requirements of Regulation of the European Parliament 2016/425. The system comprises individual ladder segments connected to each other, and mounted directly on a building and connected rail segments mounted on an existing ladder. The ladder can be equipped with access lock as door made of stainless steel secured by a padlock. Due to application of the asymmetric rail, the trolley AC 501 can be installed in only one proper configuration. The trolley is equipped with webbing energy absorber with connector AXK 10 at the end which is to be connected to front anchor point on full body harness designed for arresting a fall (according to EN 361). The upper and lower ends of the system AC 520 are provided with segments with locks (with ratchet mechanism). They protect the trolley AC 501 against accidental sliding out of the rail. In order to remove the trolley from the rail take two independent steps: first, unlock and hold the ratchet (by pulling the lever at the back of the rail within the segment with lock) and then guide the trolley through the lock by removing it from the rail. Rail vertical anchorage system AC 520 can be used by 2 users at the same time. The trolley AC 501 does not require use of any additional fall arresters. The device can be used in sub-zero temperatures (up to -30°C).



Cross section of rail guide.

Application of an asymmetric section profile improves the safety while using the system. This solution disables improper installation of the trolley.



## Installation to wall / structure

Rail systems

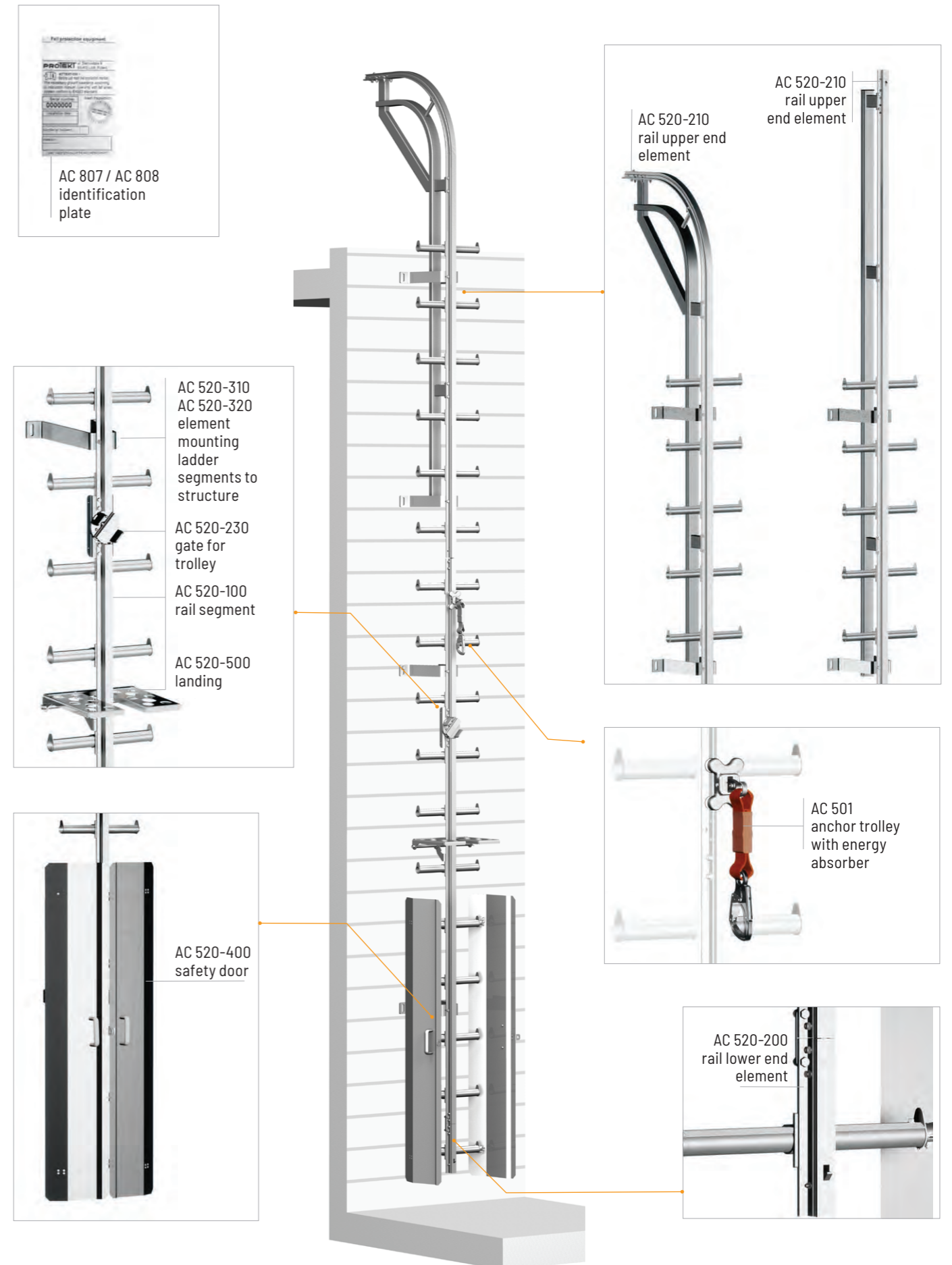

# Mounting to ladder

Rail systems

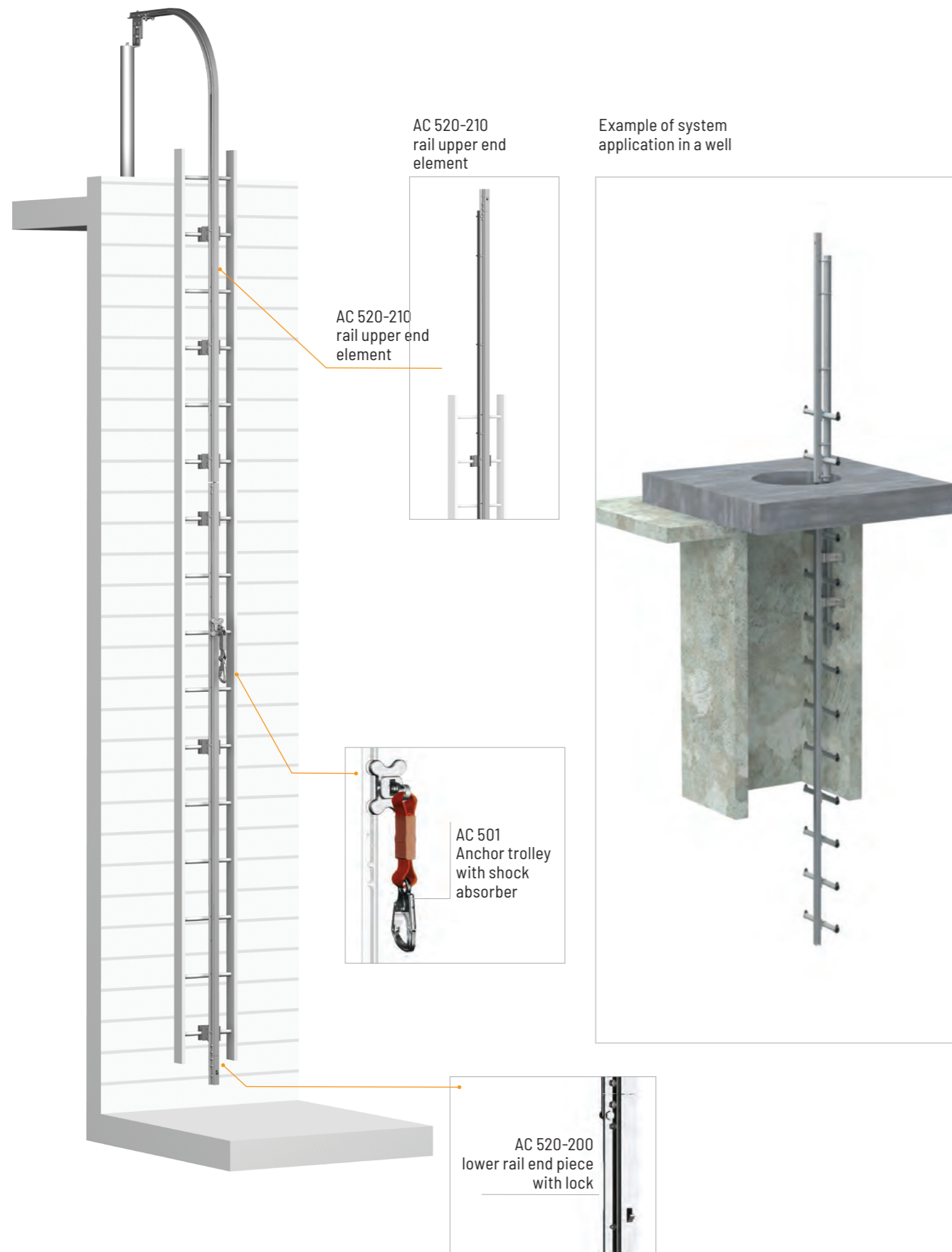

# Mounting to masonry

Rail systems

Connection to a concrete surface should be made using chemical or mechanical anchors with a tensile strength of min.12kN.

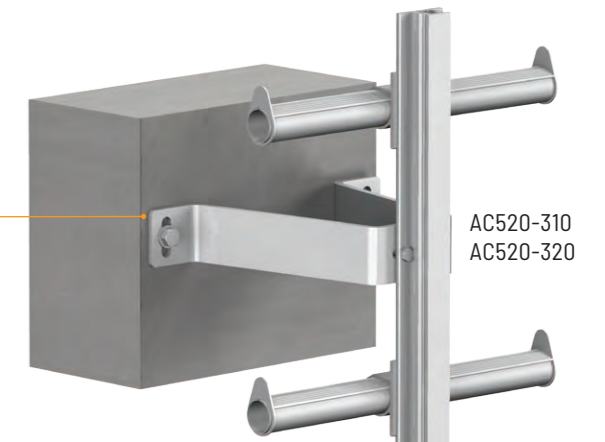
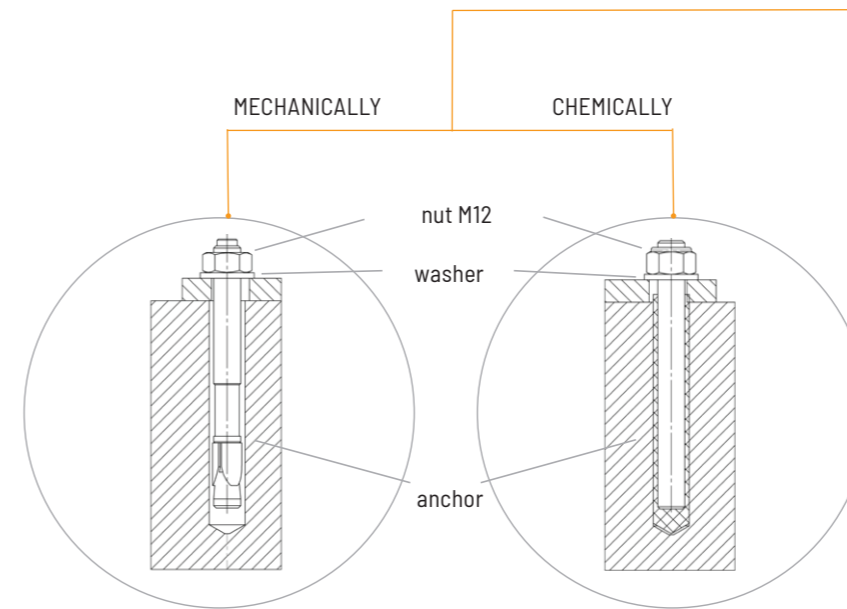

Compressive strength of the surface should be min. 25MPa. Strictly follow recommendations for installation given by manufacturers of respective anchors.

# Mounting to posts

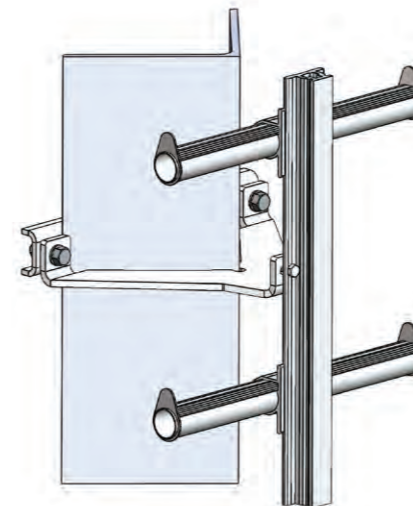

ANGLED PROFILE

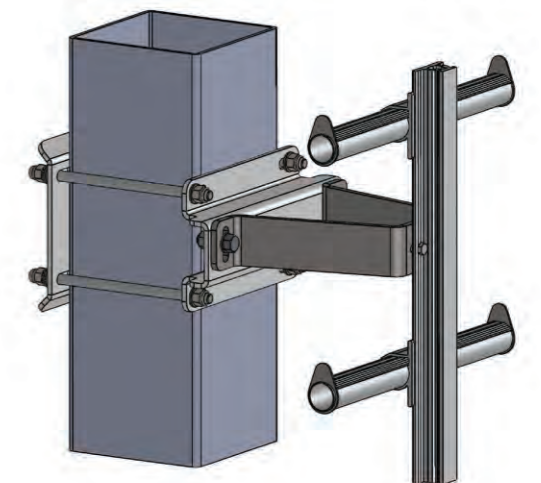



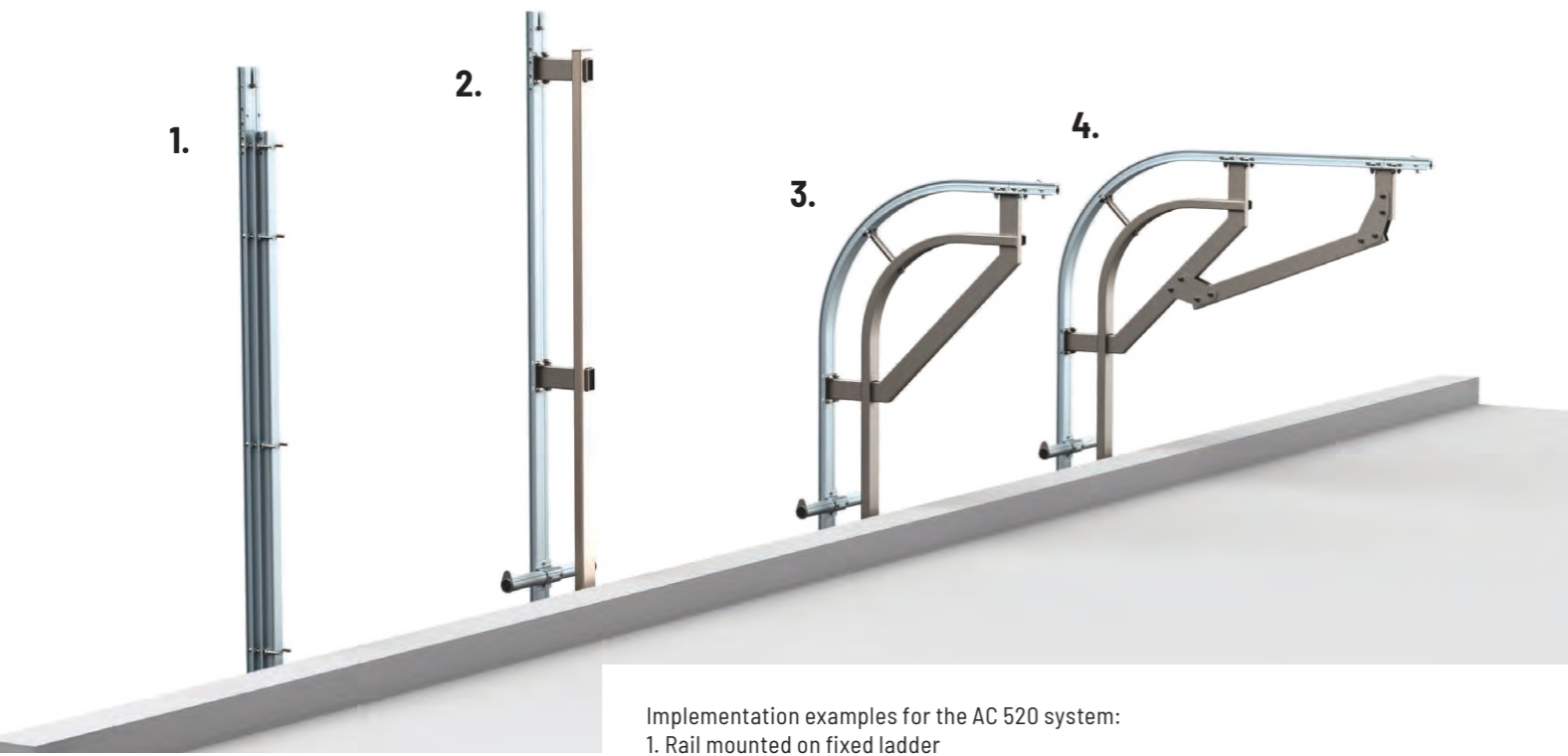





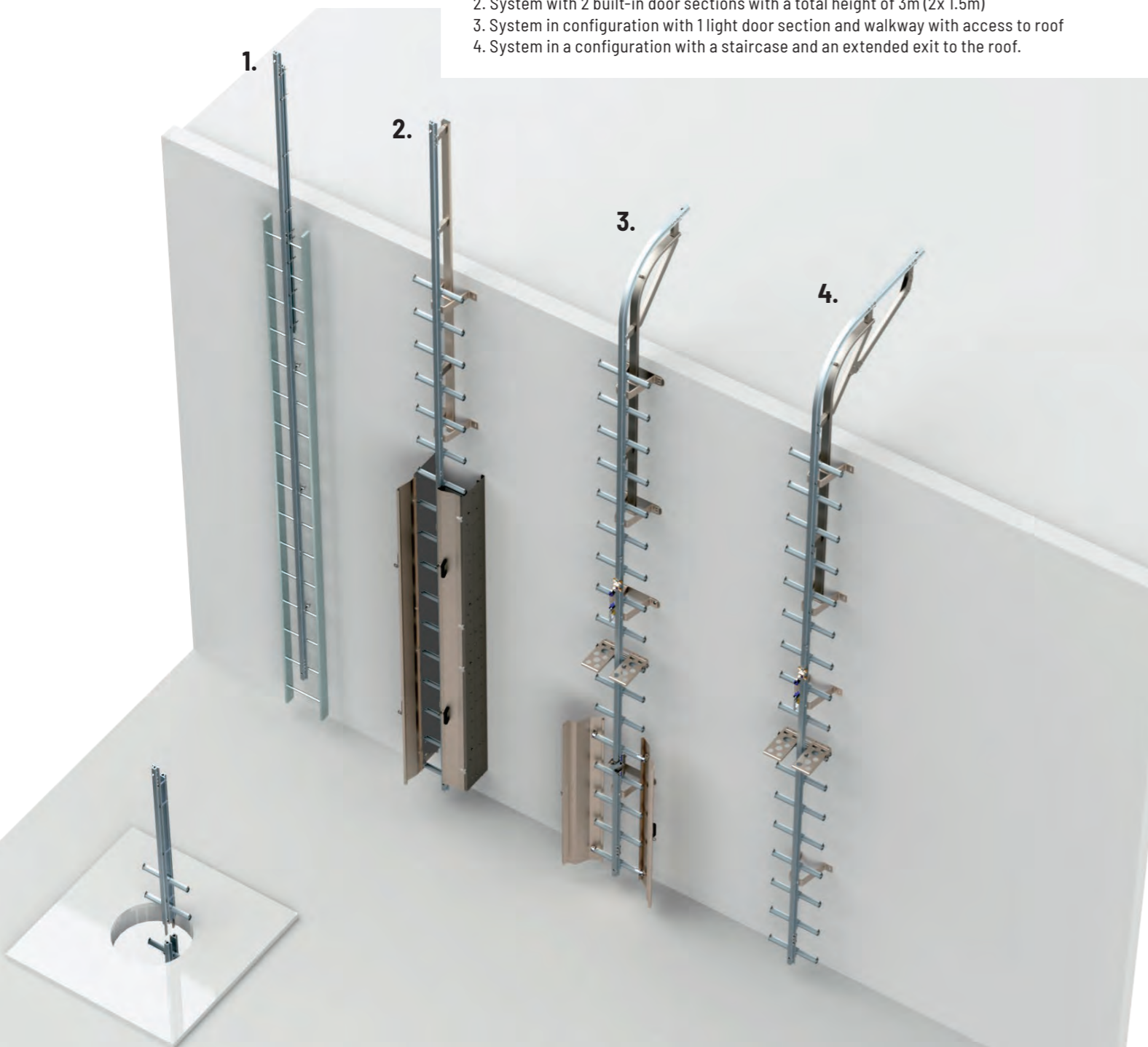











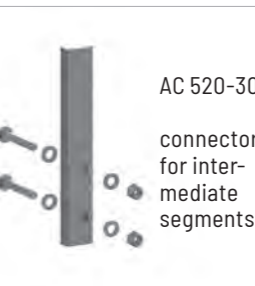
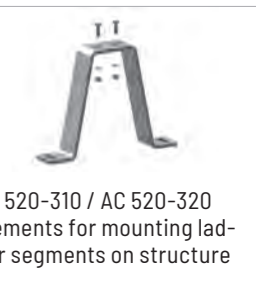

RECTANGULAR PROFILE



Implementation examples for the AC 520 system:

1. Rail mounted on fixed ladder
2. System with 2 built-in door sections with a total height of 3m (2x 1.5m)
3. System in configuration with 1 light door section and walkway with access to roof
4. System in a configuration with a staircase and an extended exit to the roof.



 <p>AC 520-100-H ladder segment (length H = 300; 270; 240; 210; 180; 150 cm)</p>	 <p>AC 520-101-H rail segment (length H = 300; 240; 180; 120 cm)</p>	 <p>AC 520-110 Ladder segment - straight exit onto roof.</p>	 <p>AC 520-111 Rail segment: straight exit onto roof</p>
 <p>AC 520-120 ladder segment (exit onto roof with bend)</p>	 <p>AC 520-121 rail segment (exit onto roof with bend)</p>	 <p>AC 520-200 rail lower end segment</p>	 <p>AC 520-210 rail and ladder upper end seg- ment</p>
 <p>AC 520-220 ladder lower end segment</p>	 <p>AC 501 anchor trolley with energy absorber</p>	 <p>AC 520-300 connector for inter- mediate segments</p>	 <p>AC 520-310 / AC 520-320 elements for mounting lad- der segments on structure</p>
 <p>AC 520-330 element for mounting rail AC 520-121 on post</p>	 <p>AC 520-340 element for mounting rail AC 520-111 on rungs [ø10 - ø40]</p>	 <p>AC 520-350 element for mounting rail (AC 520-101-H; AC 520-121) on rungs [ø10 - ø40]</p>	 <p>AC 520-400 safety door</p>
 <p>HL 704 support post for element AC 520-121</p>	 <p>AC 520-230 gate for trolley in- stallation</p>	 <p>AC 520-500 line tensioner (stainless steel)</p>	 <p>AC 807 / AC 808 informative plates (stainless steel / PVC)</p>
 <p>AC520-912-010 low support 109 mm</p>	 <p>AC 520-341 universal coupler to rungs</p>	 <p>AC 520-912-001 thrust plate made of steel stainless steel</p>	

# AC 510

Aluminium caged ladder with two uprights.



Caged ladder AC 510 conforms to: DIN 18 799-1: vertical ladders for inspection, maintenance and cleaning on civil structures. Designed for vertical mobility at various types of devices, buildings, engineering structures, etc.

Can be used at any location where it can be mounted on a fixed structure. Aluminium ladder with a cage providing protection against fall from a height. The ladder is made from aluminium profiles. The cage is made of steel, and as needed, either stainless or hot-dip galvanized steel can be used. Elements for mounting the ladder on fixed structures are made of stainless steel.

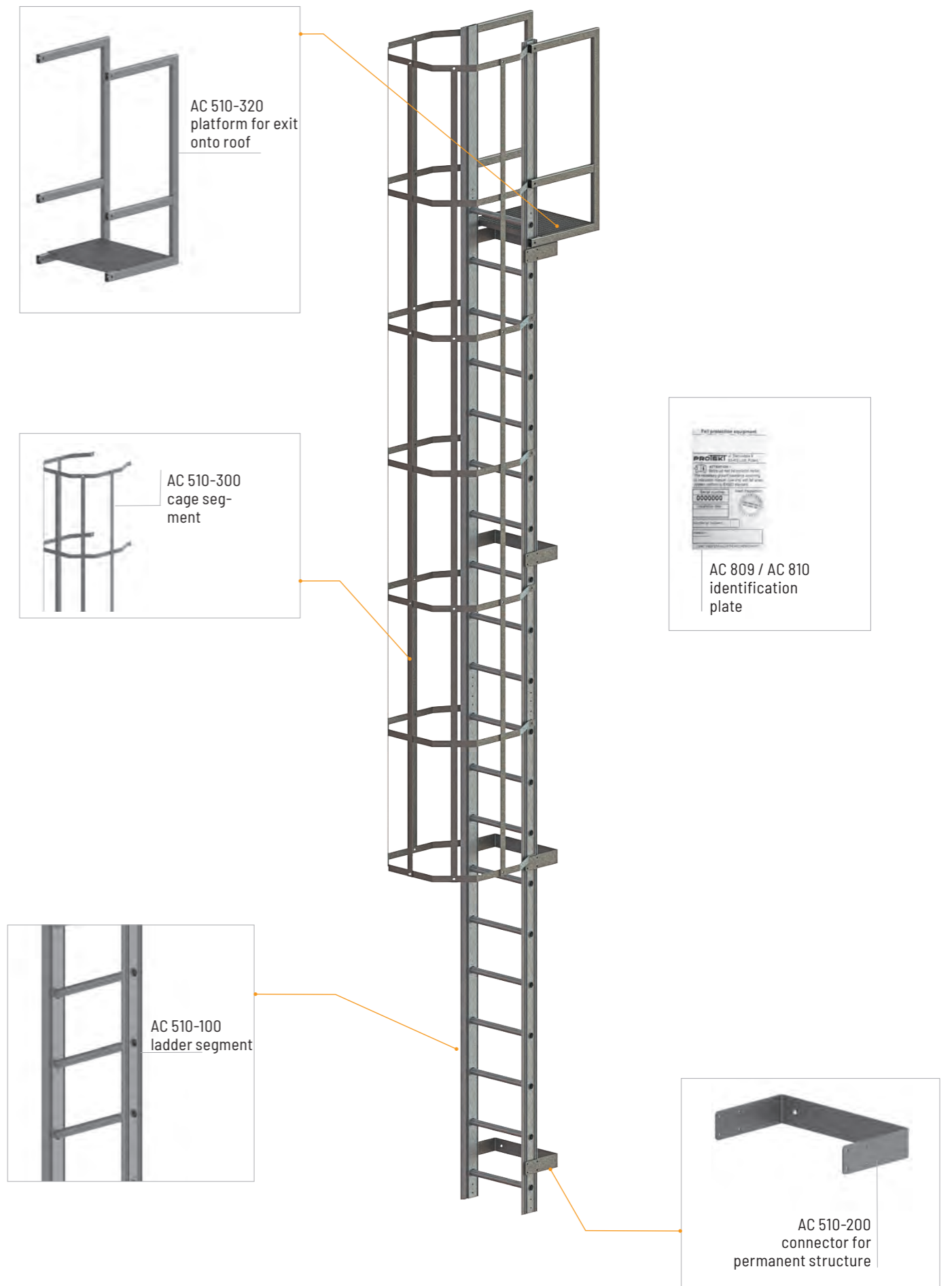

# AC 510 system components

Caged ladder



AC 510-100  
ladder segment



AC 510-200  
support



AC 510-320  
exit platform



AC 510-330  
access lock

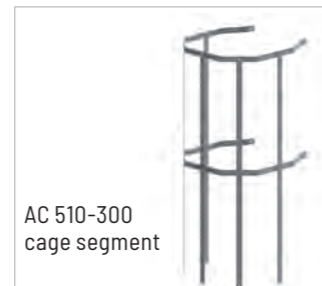

AC 510-300  
cage segment



AC 510-310  
cage rim



AC 810 / AC 809  
informative plates  
(stainless steel / PVC)



# PROSAFE

Modular free-standing  
edge guard system.



The railing system is based on counterweights made of plastic, and additionally equipped with anti-slip coating. Thanks to couplers the railings can be adopted to the roof, its curvature and difference in levels. The advantage of the modular railing system is easy handling of individual elements and simple mounting with use of only 5 types of couplers made of hot-dip galvanized steel. The heaviest element within the system weighs 24 kg, and length of the longest is 2 m. Couplers allow for arrangement of passages, gates, openings and also snow discharge areas. Owing to their versatility the railings can be adjusted to nearly any conditions. When the roof parapet is lower than 150mm, or open spaces are limited by railings, the system enables use of edge board to prevent user's feet from slipping and tools from rolling down beyond the edge.



## Weights

The railing system is based on counterweights made of plastic, and additionally equipped with anti-slip coating.

- Weight: 24kg
- Dimensions: 800x400x85
- Ergonomic carrying handle
- Available in black colour
- Made of recycled materials



## Element connections

Thanks to couplers the railings can be adopted to the roof, its curvature and difference in levels. Couplers allow for arrangement of passages, gates, openings and also snow discharge areas. Owing to their versatility the railings can be adjusted to nearly any conditions.



## Aluminium stoppers

When the roof parapet is lower than 150mm, or open spaces are limited by railings, the system enables use of edge board to prevent user's feet from slipping and tools from rolling down beyond the edge.



## Example fencing of roof with parapet

### Railing

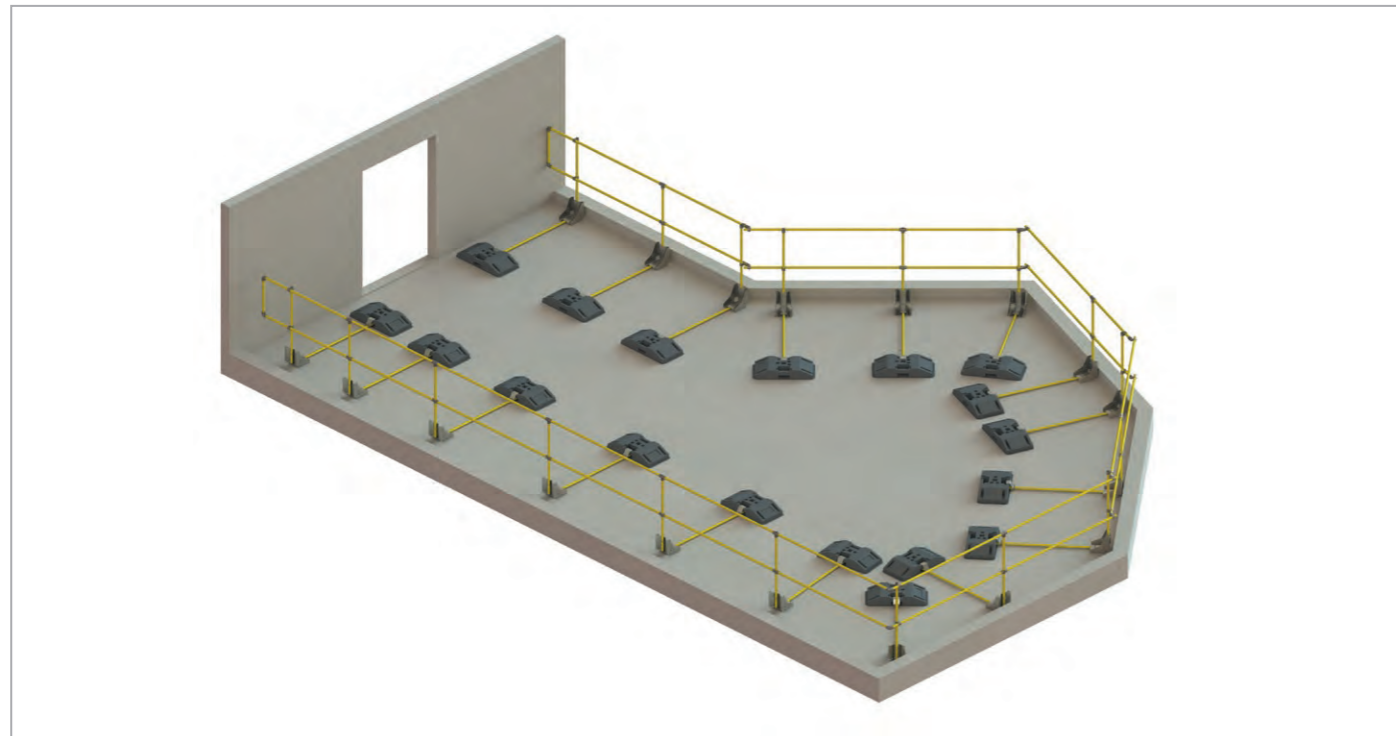

Diagram 1

## Protection of service openings

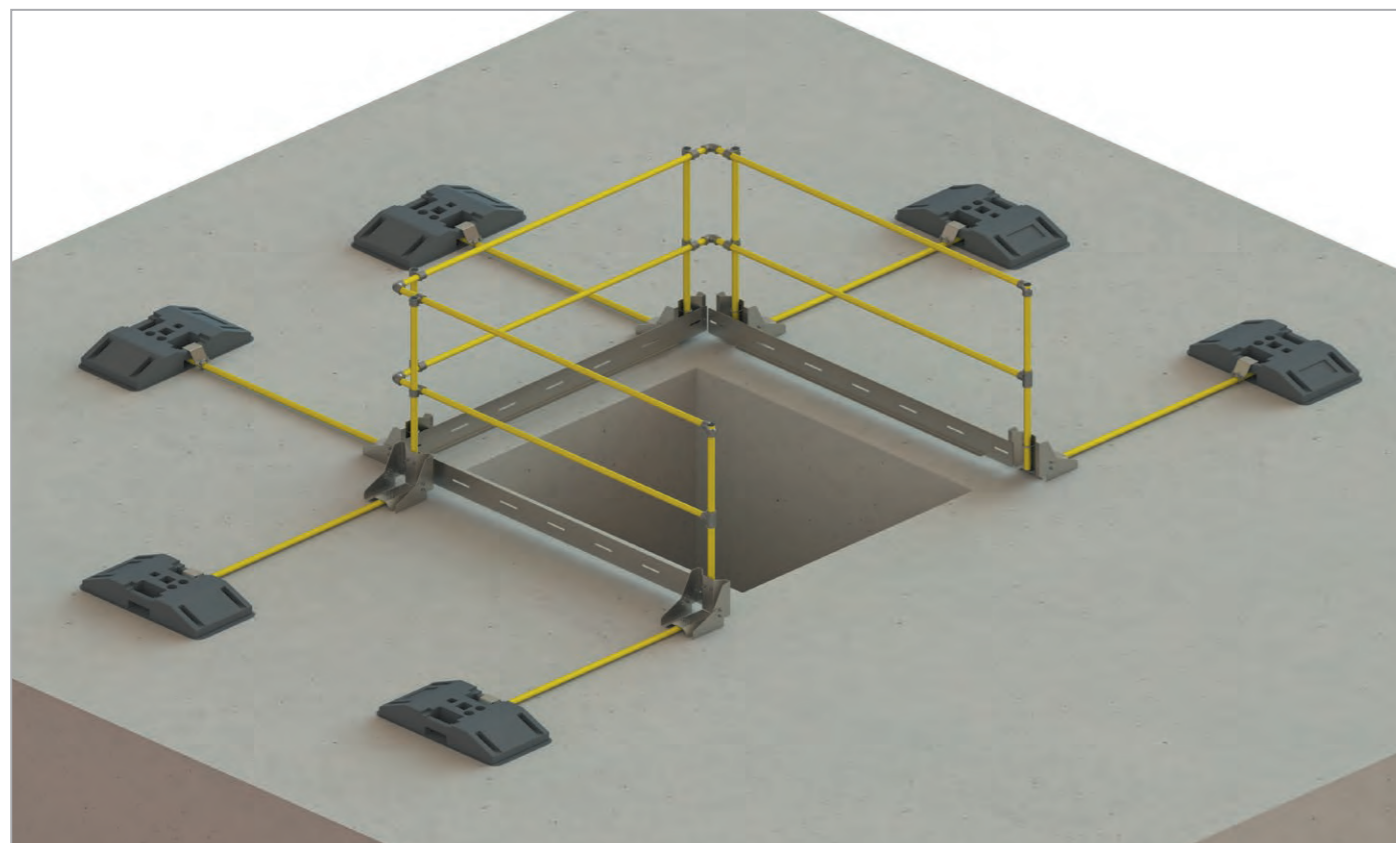

Diagram 2

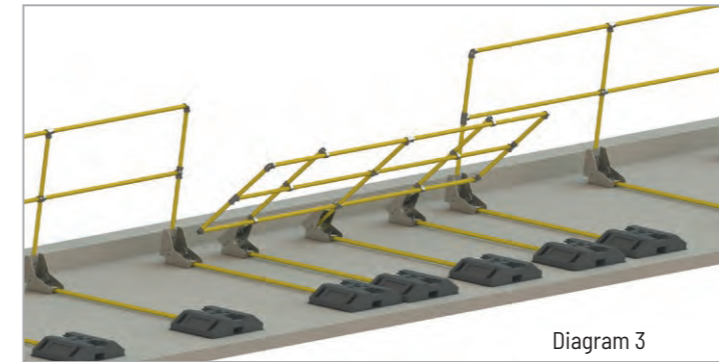

Diagram 3



Diagram 4

### Advantages of system PROSAFE:

- Passages, opened gates (Diagram 4) and snow discharge areas (Diagram 3) can be arranged.
- Inclination angle of railings can be adjusted in 15° increments within 90° inclination from vertical.
- Modular design and small number of components.
- Railing sections can be disassembled and assembled for use in other locations.
- Weather-resistant elements in contact with roof are insulated from the ground by special pads.
- No interference in roofing while assembling.
- No need of welding, bending and other fitting works on the site.

Assembly of connections with the use of a **single** Allen wrench.



Assembly of the remaining elements with the use of a **single** flat wrench.



### Technical data:

Maximum span length	2 m
Length of counterweight	1,5 m
Railing height	1,1 m
Max. space between railings	0,5 m
Weight of counterweight	24 kg
Length of the longest element	2 m
Minimum compressive strength of surface	0,6 kN/m <sup>2</sup>
Design loads applied to upper railing	300 N/m
Diameter of railings and posts	33,7 mm

Possible use **on many** types of surfaces



Assembly **does not require** any special tools nor qualifications.



# PROSAFE system components

## Railing

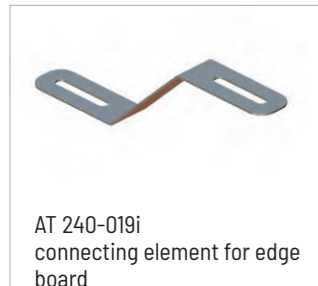
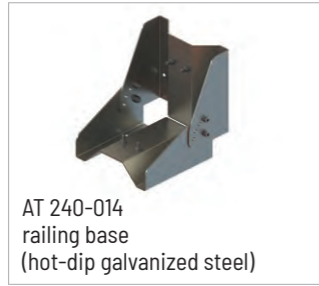



® Example configuration of PROSAFE system.

# AT 242

Skylight security system.

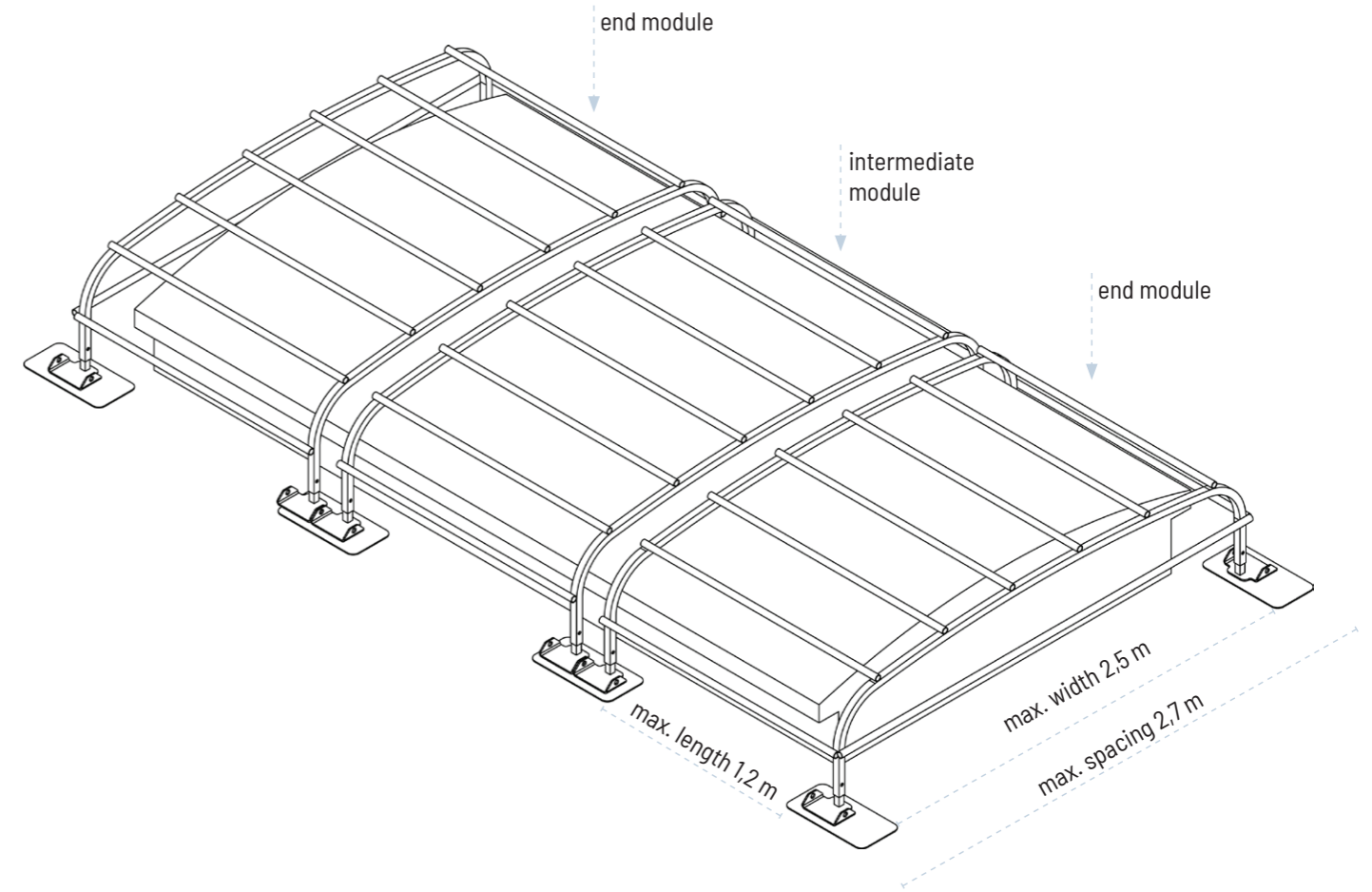

AT 242 is a system of fall protection grids (protection of skylights on flat and sloping roofs up to 15°) Installation without interfering with the roof sheathing - freestanding. The AT 242 system consists of intermediate modules and end modules with a maximum length of 1.2 m and a width of 2.5 m and legs with adjustable height.

## Skylight security system

Material:	hot-dip galvanized steel
Ability to absorb the kinetic energy of the fall: :	1400 J
Max. width of the protected skylight:	2,5 m
Max. length of the protected skylight:	1,2 m
Length:	without limits
Height:	adjustable

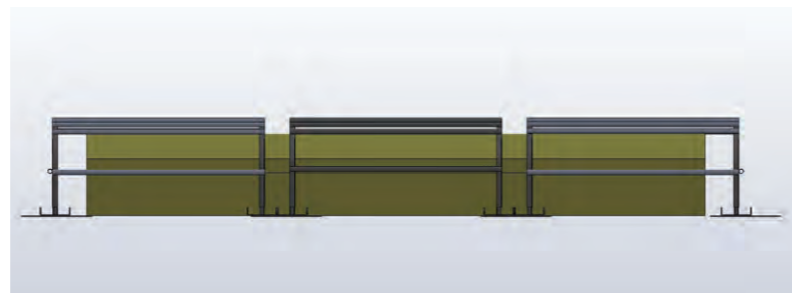
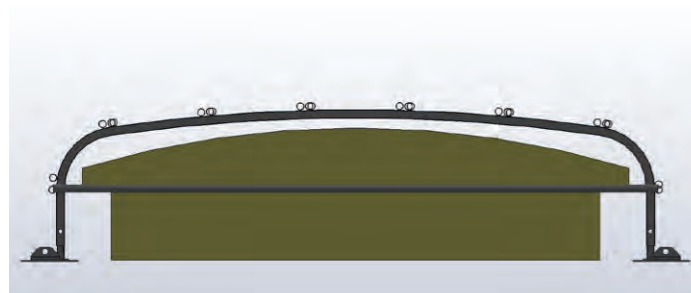

# ANCHOR MASS



Protection for  
1 user



## ANCHOR MASS IM 100

EN 795:2012 TYP E CE

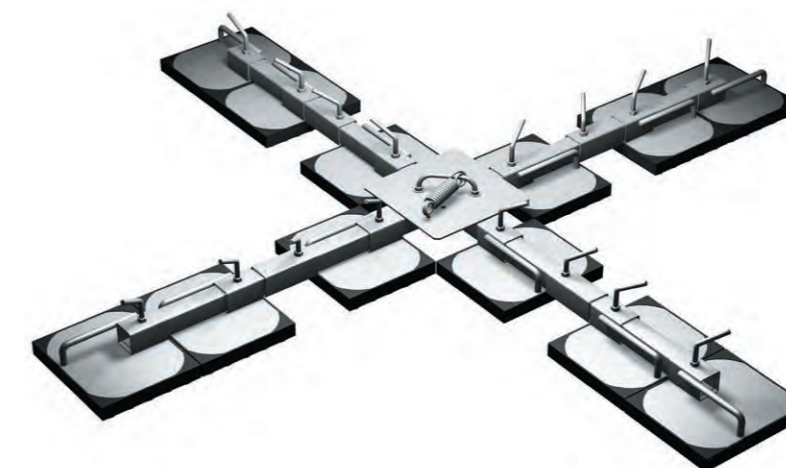

Material: hot-dip galvanized steel, rubber

Total weight: 260 kg

Weight of the weight: 18,5 kg

Dimensions: 2124 x 2124 mm

The IM 100 mass is a portable anchor point for use on a flat roof with sufficient load capacity. It consists of 12 elements (weights) and the main cross with an attachment point. Place the IM 100 in such a way that it lies exactly on the roof surface.

Protection for  
1 users



## ANCHOR MASS IM 101

EN 795:2012 TYP E CE

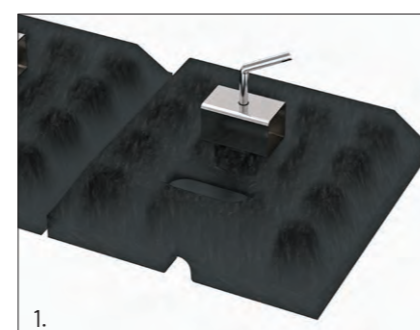

Segment (1)

Material: hot-dip galvanized steel, rubber

Total weight: 220 kg

Weight of the weight: 16 kg

Dimensions: 1550 x 1550 x 260 mm

1. Load segments of the anchor mass
2. End lock
3. Central anchor point

Protection for  
2 users



## ANCHOR MASS IM 200

EN 795:2012 TYP E CE  
EN/TS 16415:2013

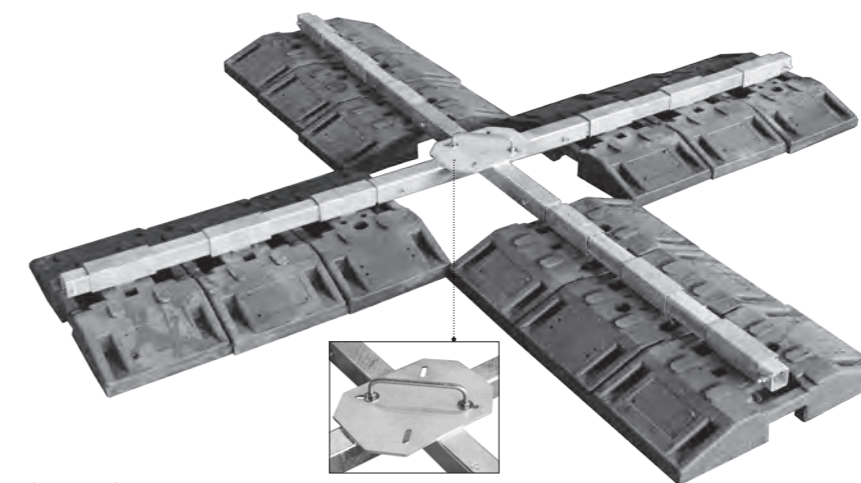

Material: hot-dip galvanized steel, rubber

Total weight: 367 kg

Weight of the weight: 25,5 kg

Dimensions: 3020,5 x 3020,5 x 400 mm

The IM 200 mass is a portable anchor point for use on a flat roof with sufficient load capacity. It consists of 12 elements (weights) and the main cross with the PROTON I post (300 mm) mounted. The IM 200 must be positioned so that it is flush against the roof surface.





® Example configuration of PRIM system.